

# **PRODUCT SUPPORT MANUAL**

Y1-03-0157  
Rev. C



GlobalFix™ 406 MHz  
RLB-35

Emergency Position  
Indicating Radio Beacon  
FCC Type Accepted

Product No. 2742 Cat. I  
Product No. 2744 Cat. II

Owner	_____
Vessel	_____
Radio CallSign	_____

**ACR Electronics, Inc.**  
5757 Ravenswood Road  
Fort Lauderdale, Fl 33312  
+1(954) 981-3333 • Fax +1 (954) 983-5087  
www.acrelectronics.com  
Email: Info@acrelectronics.com

**\*\*\* WARNING \*\*\***  
**THIS TRANSMITTER IS AUTHORIZED FOR USE**  
**ONLY DURING SITUATIONS OF GRAVE**  
**AND IMMINENT DANGER**

---

**DELIBERATE MISUSE MAY**  
**INCUR A SEVERE PENALTY**

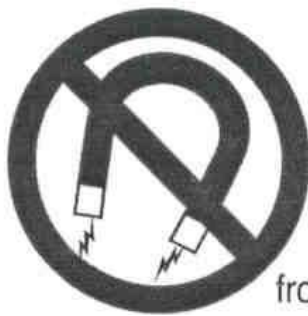

**Magnet**  
**safe distance**  
**1 m (3.3 ft)**

---

Keep this container  
a safe distance away  
from all magnetic sources.



**Stereo Speaker**  
**safe distance**  
**1 m (3.3 ft)**

---

Keep this container  
a safe distance away  
from all stereo speakers.

## Forward

Congratulations and thank you for purchasing the ACR **GlobalFix™ 406** Emergency Position Indicating Radio Beacon. The combination of superior design, high quality raw materials and quality controlled manufacturing produce a product that will perform for years to come. The Test Facility at ACR can reproduce some of the harshest environmental conditions known to man. This assures that the products we produce can stand up to the rigors found in a marine environment. With proper care and maintenance, your EPIRB will be in service for years to come.

ACR is proud to be certified to the ISO 9001, the International Standard for Quality.

This manual provides installation, operation and maintenance instructions for the **GlobalFix™ 406** EPIRB, hereinafter referred to as the Beacon. This manual also describes the characteristics and details of the Beacon System. The FCC authorizes the use of 406 MHz Radio Beacon by any ship that is also equipped with a VHF Ship Station. This will make the 406 MHz Radio Beacon available for use on most U.S. ships and boats. EPIRB carriage requirements are contained in USCG regulations.

## Table of Contents

1.0	Registration.....	3
2.0	False Alarms.....	4
3.0	Installation.....	5
4.0	Operation.....	8
5.0	Care and Maintenance.....	13
6.0	The Search and Rescue System.....	14
7.0	Authorizations, specifications and warranty.....	16
	Figure 1.....	15
	Figure 2.....	16
	Figure 3.....	19
	Figure 4.....	20
	Figure 5.....	21
	Declaration of Conformity.....	22

## **SECTION 1 - REGISTRATION OF 406 MHZ BEACONS**

### **1.1 Registration Importance**

It is imperative that the owner of this 406 MHz Beacon registers it with the National Authorities.\* All 406 MHz Beacons transmit a Unique Identifier Number (UIN) when activated. This UIN is programmed in the Beacon based on the country in which the Beacon was purchased. Registration provides the Search and Rescue forces with up to date emergency contact information, which will speed up the launch of a rescue operation. The National Authorities use the information to verify if an actual emergency exists. Valuable Search and Rescue resources are wasted every year responding to false alarms. For Beacons that are not registered, SAR forces will not know who you are, what type of vessel you have, your homeport, or who to contact that might know of your current situation. This will delay the launch of a rescue operation.

\* National Authority is the governmental body that is responsible for EPIRB Registration Database administration for the country the EPIRB is programmed for.

### **1.2 Where to register**

The owner of a 406 MHz Beacon (EPIRB) should register it with the National Authority of which the Beacon was programmed, (typically the country where purchased), regardless of where they do their boating. Each Beacon is programmed with a UIN for the country that the unit is shipped to, and will only be accepted for registration in that country. To verify the country, for which a Beacon is programmed, see the label with the UIN on the side of the unit. Units that do not have a country specified on the UIN label are programmed for the United States.

### **1.3 Registration in the United States**

It is the Owner's responsibility to Register 406 MHz Beacons that are programmed for and purchased in the United States. The National Authority that accepts registrations in the United States is the National Oceanic and Atmospheric Administration (NOAA). The owner should complete the enclosed registration form (Do not confuse this with the ACR Electronics Warranty Card) and mail with the pre-addressed; postage paid envelope to:

SARSAT Beacon Registration,  
E/SP3, RM 3320, FB-4  
NOAA/NESDIS  
5200 Auth Rd.  
Suitland, MD 20746-4304

Register online at: [www.beaconregistration.noaa.gov](http://www.beaconregistration.noaa.gov)

The information provided on the Registration Form is used only for rescue purposes. The Registration Form should be filled out and mailed immediately. Registration can be expedited by faxing the registration form to Fax # (301) 568-8649 or register online. Registrations should be completed online or faxed in the event the Beacon is to be placed in immediate service and followed up with the mailing of the hard copy form.

All registration forms will be entered in the 406 MHz Beacon Registration Database within 48 hours of receipt. A confirmation letter, a copy of the actual registration and a proof-of-registration decal

will be mailed to you within two weeks. When you receive these documents, please check the information carefully and affix the decal to your beacon in the area marked “Beacon Decal here”. If you do not receive confirmation back from NOAA, Please call toll free 1-888-212-7283 for assistance.

### **1.3.1 Commercial Vessels in the United States**

In the United States, commercial vessels that are required to have a Radio Station License are required to modify that license when an EPIRB is added to the vessel. Please use the enclosed FCC FORM 506 to modify your Radio Station License. For information on whether you need a Radio Station License, call toll free 1-888-CALLFCC (225-5322)

### **1.4 Registration Outside of the United States**

In countries other than the United States, 406 MHz Beacons are registered with that country’s National Authority at the time of Purchase. The Sales agent should assist in filling out the forms and sending to that country’s National Authority. To verify that the unit is properly programmed for that country, view the UIN label on the side of the unit. In the event that the Beacon is not programmed for the country it has been purchased in, the sales agent, (if properly equipped) can reprogram the unit for that country.

### **1.5 Change of ownership or contact information**

It is the owner’s responsibility to advise the National Authority of any change in the information on the registration form. If the current owner of the Beacon is transferring the Beacon to a new owner, the current owner is required to inform the National Authority by Letter, Fax or telephone, of the name and address of the new owner. The new owner of the Beacon is required to provide the National Authority with all of the information requested on the Registration form. This obligation transfers to all subsequent owners. Registration forms are available from NOAA. Call 1 (888) 212-7283 or visit our website at [www.acrelectronics.com](http://www.acrelectronics.com).

### **1.6 Commercial Vessels World Wide**

406 MHz Beacons that are carried on commercial vessels world wide, should be registered with the country where the vessel is flagged regardless of where the vessel operates. When a commercial vessel acquires a 406 MHz Beacon from outside of its home country; the Beacon should be reprogrammed for the home country and registered there.

## **SECTION 2 - FALSE ALARMS**

### **2.1 Prevention of false alarms.**

An ACR 406 MHz EPIRB can be activated by two different methods. Whether you have a Category I or II; these methods are the same.

1. When the beacon is out of its bracket and in the water, the unit is transmitting.
2. When the switch is moved to the on position, in or out of the bracket, the unit is transmitting.

There are a few precautions that should be taken to prevent false alarms.

- Do not transport Beacon within 1 meter (3.3ft) of a magnetic source.**
- Do not mount Beacon within 1 meter (3.3ft) of a magnetic source.**
- Do not store Beacon outside of its bracket if it can get wet.**
- Do not clean Beacon with a water hose and brush.**

## **2.2 Reporting of false alarms**

Should there be, for any reason, an inadvertent activation or false alarm, it must be reported to the nearest search and rescue authorities. The information that should be reported includes the EPIRB Unique Identifier Number (UIN), Date, Time, duration and cause of activation, as well as location of beacon at the time of activation.

### **2.2.1 To report false alarms in the United States contact any of the following:**

Atlantic Ocean / Gulf of Mexico  
USCG Atlantic Area Command Center  
Tel: (757) 398-6390

Pacific Ocean Area \ USCG Atlantic Area Command Center  
Tel: (510) 437-3700  
From Any Location

USCG HQ Command Center  
Tel (800) 323-7233

### **2.2.2 To report false alarms worldwide contact your national authority.**

## **SECTION 3 - INSTALLATION (Product No. 2742 and 2744)**

### **3.1 Mounting Location (Product No 2742 and 2744)**

- 3.1.1 The location selected must be sufficiently rigid to support the weight of the total installation and at the same time consider vibration, exposure to the elements, exposure to surrounding hazards, such as equipment movement, doors being opened, accidental covering, personnel traffic, etc., and yet be readily accessible at all times for the emergency use for which the beacon is intended.
- 3.1.2 Also to be considered in selecting a location for installation is the harmful effect that certain corrosive vapors might have on the beacon. Under no circumstances should a location be selected for installation where the beacon would be jeopardized by any foreign articles being temporarily or permanently positioned during “at sea” or “in port” activities.

**CAUTION:** Care must be taken to prevent any lanyard, line, or other emergency equipment that may be attached to the beacon from becoming entangled or fouled which could prevent the beacon from being removed in an emergency.

- 3.1.3 Do not mount the **GlobalFix™ 406** in the vicinity (3.3 ft.) of strong magnetic (such as loud speakers) or electrical (such as radar or high power radio transmitter) fields. The beacon should not be mounted closer than (3.3 ft) to a navigation compass.
- 3.1.4 Consideration should be given to mounting the **GlobalFix™ 406** in a vertical (antenna upward position). In certain circumstances, such as medical emergencies or disabled vessels, manual activation of the EPIRB for location and homing purposes is sometimes requested. Mounting in this orientation provides the best homing signal.
- 3.1.5 The **GlobalFix™ 406** (Product No. 2742) Cat. I float-free mounting bracket should be mounted securely to a *vertical or horizontal surface* (the mount has predrilled holes for attachment to a flat surface) where there are no overhead obstructions. Location aboard a vessel must be chosen to allow the EPIRB to float free of sinking craft and as high as possible especially on small vessels. This will help ensure operation of the hydrostatic release unit in the event the vessel capsizes without sinking.
- 3.1.6 The **GlobalFix™ 406** (Product No. 2742) Cat. I float-free mounting bracket should be securely attached to the vessel. The use of #10 stainless steel hardware is recommended. To access third mounting hole it is necessary to remove the hydrostatic release and allow spring to deploy. Hold spring with one hand and slide hydro up into keyway. Be careful to release spring slowly. Mount bracket to wall and reassemble. *See Figures A, B and C.*



**Figure A**



**Figure B**



**Figure C**

## 3.2 Visual Inspection

- 3.2.1 Visually inspect the area surrounding the mounting bracket installation site for hidden hazards, obstacles, etc., that may have been overlooked during selection. If there is any doubt as to the ready accessibility to the beacon at all times or if any condition may appear to be questionable, make complete and thorough investigation before making final approval of the installation.

## 3.3 Hydrostatic Release Dating Instruction (Product No. 2742) Cat I.

- 3.3.1 The label on the hydrostatic release mechanism inside of the bracket and the replacement date label on the outside of the bracket **MUST** be marked with the date of expiration at time of installation according to coastal marine authority regulations.

To record the expiration date on the hydrostatic release mechanism, remove the perforated dates of the label to indicate the month and year two years from date of installation. Write the date of expiration with an indelible marker on the label appearing on the outside cover.

## SECTION 4 - OPERATION

### 4.1 General

- 4.1.1 The **GlobalFix™ 406** Beacon Model (Product No. 2742) Cat. I is designed to be automatically deployed and activated. The **GlobalFix™ 406** may also be hand held on the deck of vessels, or floated in water and attached to a raft or life vest with the lanyard provided. The **GlobalFix™ 406 is designed to operate best while floating in water.** Hand held operation should be avoided when possible. (Product No. 2744) Cat II is designed to be manually deployed from its bracket. Do not operate inside liferaft or under any similar cover or canopy. Use the lanyard to attach beacon to life raft or person after deployment. **Caution** - *Do not attach lanyard to bracket or vessel.*
- 4.1.2 Both models of the **GlobalFix™ 406** Beacon can be deployed and activated manually.
- 4.1.3 Changes in the laws governing beacons have mandated that the beacon be armed at all times. If certain criteria are met, the beacon will begin transmitting.

The **GlobalFix™ 406** is equipped with sensors to detect when it is no longer in its bracket (a deployment condition) and other sensors to determine if it is in water.

Two conditions must be satisfied for the **GlobalFix™ 406** to automatically activate:

- 1) It must be out of its bracket,
- 2) It must be in the water,

Note: Either condition by itself will *not* automatically activate the beacon.

- 4.1.4 The **GlobalFix™ 406** is designed to allow the user to perform periodic testing while EPIRB is in the release bracket to assure a functioning beacon.
- 4.1.5 Place the **GlobalFix™ 406** (Product No. 2742) into the release bracket with the coiled lanyard inward. The beacon should now be firmly held in the Cat I bracket and ready for automatic deployment. Do not attach lanyard to bracket.

4.1.6 Place the **GlobalFix™ 406** (Product No. 2744) into the bracket with the coiled lanyard inward. The beacon should now be firmly held in the Cat. II bracket and ready for manual deployment. Do not attach lanyard to bracket. Use the strap and buckle to secure the beacon.

## 4.2 Automatic Deployment and Activation (Cat. I and Cat. II)

(Product No. 2742 *only*)

4.2.1 Automatic deployment and activation occurs when the vessel sinks and a hydrostatic release device frees the beacon from the bracket allowing it to float to the surface. Built-in sensors detect that the beacon is no longer in its bracket and is in water. This condition will automatically activate the beacon.

Note: Transmissions of the 121.5 MHz and 406 MHz signal will not occur until 100 seconds after activation.

Product number 2742 **GlobalFix™ 406** (Cat. 1) may be deployed and activated automatically by the built-in hydrostatic float free release. Once free from the release bracket, the **GlobalFix™ 406** will automatically turn on if the water sensors are wet.

## 4.3 Manual Deployment and Activation, (Cat. I and Cat. II)

4.3.1 The **GlobalFix™ 406** (Product No. 2742) Cat. I can be manually deployed by removing the retaining pin, removing the cover, then removing the beacon from the bracket. Once removed, either Cat I or Cat II beacons can be activated by being placed in water or by lifting the thumb switch towards the antenna, sliding it toward the antenna and placing the thumb switch back down on the opposite side of the EPIRB. Activating the beacon in this manner breaks off the Activation Indicator Plastic Pin and exposes the "ON" symbol " ■ " on the thumb switch indicating that the beacon is turned "ON". (See Figures D, E, F and G)

Note: Some countries may fine vessel owners for causing false alarms. The permanent breakage of the Activation Indicator Plastic Pin is a positive indication of a manual activation. (See Figure I).

Alternately, the **GlobalFix™ 406** can be manually activated by lifting the thumb switch to a vertical position, sliding it toward the antenna and pushing back down to the opposite side of the EPIRB. Activating the beacon in this manner breaks off the "Activation Indicator Plastic Pin" and allows the switch to properly seat, showing the " ■ " symbol (ON).

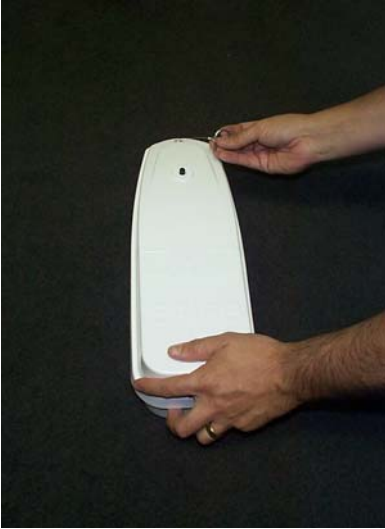

**Figure D**



**Figure E**



**Figure F**



**Figure G**



**Figure I**

## 4.4 Manual Activation Without Deployment

4.4.1 The **GlobalFix™ 406** can be activated while still in its bracket by placing the thumb switch in the ON position. Activation by this method overrides all sensors and turns the beacon “ON”.

The caution note above still applies.

## 4.5 Deactivation

4.5.1 The **GlobalFix™ 406** can be deactivated by:

If manually activated:

- 1) Returning the thumb switch to the “OFF” position.

If automatically activated:

- 1) Removing the beacon from the water. The beacon normally takes up to 12 seconds to deactivate, or
- 2) Placing the beacon back into the release bracket.

4.5.2 If the beacon continues to operate after it has been deactivated, remove the four screws holding the unit together and unplug the battery to disable the unit. Return it to a Service Center for repair.

## 4.6 Full Functional Self Test

Please read all instructions before performing any of the tests. Be prepared to record data from the test.

4.6.1 Self-test is initiated by momentarily lifting the thumb switch to a vertical position and holding it in this position for at least two seconds and at most 4 seconds. A beep and the simultaneous lighting of the red LED indicate the initiation of the test. The buzzer will beep an additional four times as the red LED lights simultaneously. The **green** LED will then light, followed by a flash of the strobe, indicating a successful test. During self-test, an actual satellite message is transmitted while certain key performance parameters are measured and recorded. The self-test message is modified to prevent the satellite from forwarding an alert message during self-test. (See *Figure H*)



**Figure H**

The **GlobalFix™ 406** can be tested in or out of the release bracket.

The sequence of tests is:

1. Check Data Integrity..... Beep and lights up red LED if passed  
..... Stop if failed
2. Check 406 MHz Synthesizer ..... Beep and lights up red LED if passed  
..... Stop if failed
3. Check RF Power/Battery ..... Beep and lights up red LED if passed  
..... Stop if failed
4. Check internal GPS ..... Beep and lights up red LED if passed  
..... Stop if failed
5. Turn on green LED to indicate Successful Test.
6. Flash Strobe Light to test Strobe.

*If all of the above occurs, the test has been successful.*

NOTE: The homing beacon at 121.5 MHz is inhibited during self test.

- 4.6.2 It is strongly recommended to perform the full functional self test on the **GlobalFix™ 406** on a monthly basis.

If the thumb switch is accidentally or inadvertently put in the vertical or test position (not in the OFF or ON position), the beacon would still be turned ON and would drain the battery. That this should happen accidentally or inadvertently is very unlikely. However, if this should occur, the beacon will sound a beep once per second and will alternately flash the red and green LED's at a rate of one per second until the beacon is turned OFF. It is important that the beacon be turned OFF immediately (lowering the thumb switch to the OFF position, thumb switch at rest in the front position) if this alert is ever obtained.

#### 4.7 Internal GPS Test

**Warning:** The following test should never be performed more than once during the five-year life of the battery pack! Send the unit to ACR if test needs to be repeated.

- 4.7.1 The **GlobalFix™ 406** is fitted with an internal Global Positioning System receiver that will determine the navigational coordinates, latitude and longitude, of its position on the globe to be transmitted to the emergency system. When the **GlobalFix™ 406** is turned ON, the GPS is immediately turned ON and it immediately begins acquiring data. Initially the red LED, Light Emitting Diode, flashes once per second to indicate the **GlobalFix™ 406** is turned ON and operating. As soon as the GPS receiver acquires good navigational data the red LED stops blinking and the green LED flashes once per second to indicate that the internal GPS receiver has acquired good navigational data. Once good navigational data has been obtained the GPS receiver waits for 20 minutes before looking for new navigational data again. If for any reason a time period of 4 hours passes without the GPS receiver being able to update the last good set of navigational data, the message transmitted by the **GlobalFix™ 406** will revert back to default data. At this point the green LED will stop blinking and the red LED will flash once per second. If at any time after this, good navigational data is obtained, this data will be transmitted, the red LED will stop blinking and the green LED will flash once per second.

## 4.7.2 Performing the Internal GPS test

If the thumb switch is held in the vertical position after the full functional self-test has finished, the buzzer will beep and the red LED will light simultaneously. This beep and simultaneous red LED indicates that the GPS has been turned ON and a live test of the internal GPS has begun. At this point the thumb switch should be allowed to return to its normal OFF position. The GPS will remain ON until good navigation data has been obtained or until 10 minutes has elapsed. If good navigation data has been obtained, the GPS will be turned OFF and the green LED will light for at least 3 seconds and the strobe will flash once. This navigation data is not saved for use when the beacon is turned ON. A green LED and strobe flash indication is proof that the GPS is functioning properly and that the beacon is in a location or environment where it can receive the necessary signals from satellites. If the GPS does not acquire good navigation data, the GPS will turn OFF after 10 minutes and there will be no successful green LED indication. This test should never be performed more than once during the five-year life of the battery pack to prevent excessive current drain! **The beacon must remain under observation to witness the results of the test.**

## SECTION 5 - CARE AND MAINTENANCE

- 5.1 At least every ninety days, the float free mounting bracket and **GlobalFix™ 406** EPIRB should be inspected for deterioration and/or buildup that may affect the function of the beacon or automatic release.

Also carefully inspect the EPIRB case for any visible cracks. Cracks may admit moisture, which could falsely activate the beacon or otherwise cause a malfunction. Any cracking observed should be immediately referred to ACR for evaluation, (1-800-432-0227 Ext. 112)

- 5.2 Clean the beacon and the mounting bracket to remove residue buildups. It is recommended that the mounting bracket be wiped with a damp cloth.
- 5.3 The hydrostatic release unit (HRU) must be replaced by the date indicated on the float free mounting bracket. The hydrostatic release can be replaced by removing the Beacon from the bracket, then sliding the hydrostatic release assembly out of the keyed opening on the spring and mounting bracket. Insert the new hydrostatic release assembly, in place by engaging it to the opening of the ejection spring and case. When servicing the HRU, ACR requires that you replace the entire hydrostatic assembly, including hydrostatic release, release rod and all hardware (**P/N 9367 or P/N 9402 Universal kit**). Failure to replace the entire assembly can cause the bracket to malfunction. Always use original ACR replacement parts. Use of unauthorized replacement parts will void your warranty and may cause the bracket to malfunction. Place beacon into the mounting bracket, and replace cover, securing in place with hitch pin going through the hydrostatic release rod.
- 5.3.1 Check antenna for tightness.
- 5.4 The battery (P/N 1098) must be replaced by the date indicated on the beacon. At each inspection, check the time remaining until replacement is required. Battery should be replaced if the beacon has been activated for any use other than the self test.

NOTE: There are no user serviceable items inside the EPIRB. **DO NOT OPEN THE EPIRB UNLESS TO DISABLE IN CASE OF FAULTY ACTIVATION.**

Self contained long life batteries with a five-year recommended replacement cycle provide power. *See Factory Authorized Service Center for replacement.*

Battery replacement includes servicing the EPIRB by replacing all o-rings, testing the water seal and the electrical properties.

Always refer all long life battery replacement and other EPIRB service to a factory authorized service center.

For the nearest location of a factory authorized service center, call 1-800-432-0227 Ext. 112 (toll free) or visit our website at [www.acrelectronics.com](http://www.acrelectronics.com)

- 5.5 The **GlobalFix™ 406** contains lithium batteries which meet the requirements of the DOT Hazardous Materials Regulations. They also meet the United Nations Classification of Lithium Batteries for Shipment as "Non – Dangerous Goods".

## SECTION 6 - THE SEARCH AND RESCUE SYSTEM

- 6.1 The **GlobalFix™ 406** Beacon provides distress alerting via radio transmission on 406 MHz to satellites of the COSPAS-SARSAT network and to the GEOSAR network that includes GPS latitude and longitude coordinates.

- 6.1.2 The message transmitted by the **GlobalFix™ 406** is unique for each EPIRB, which provides identification of the transmitter through computer access of registration files maintained by the National Oceanic and Atmospheric Administration or other national authority. **It is the user's responsibility to fill out and mail the enclosed registration form to the appropriate agency of the country under which the beacon is programmed** *See Section 1.* **Remember**, if your EPIRB is **not registered**, SAR Authorities do not know who you are, what type of vessel, your homeport, or where to contact anyone who might know anything about your situation.

- 6.1.3 Once the **GlobalFix™ 406** signal (406 MHz) is relayed through the COSPAS-SARSAT and/or GEOSAR network alert, Search and Rescue (SAR) forces, can converge on the GPS navigation position. When the **GlobalFix™ 406** is used, SAR authorities can know your precise location immediately and speed up the launch of a rescue mission. The **GlobalFix™ 406** on-board radio beacon transmitter (121.5 MHz) and high intensity xenon strobe light aid intermediate and short-range location.

### 6.2 Satellite Detection

- 6.2.1 The **GlobalFix™ 406** transmits an encoded phase modulated radio signal to the satellite portion of the COSPAS-SARSAT System. The system was developed and implemented by the COSPAS-SARSAT Partners (Russian Federation, Canada, France and the United States).

- 6.2.2 COSPAS-SARSAT is an international system that uses Russian Federation and United States low altitude, near-polar orbiting satellites that assist in detecting and locating activated 121.5/243 MHz EPIRBs and 406 MHz Satellite EPIRBs. The Russian Federation provides aboard COSMOS navigation spacecraft COSPAS payloads that are inter-operable with the SARSAT System. In addition to weather and environmental sensors, SARSAT payloads, provided by Canada and France,

are carried aboard the United States National Oceanic and Atmospheric Administration's (NOAA's) Advanced TIROS environmental satellites. (See Figure 1: Satellite Detection)

- 6.2.3 COSPAS and SARSAT satellites receive distress signals from satellite EPIRBs transmitting on the frequency of 406.025 or 406.028 MHz. The COSPAS-SARSAT 406 MHz satellite EPIRB signal consists of a transmission of non-modulated carrier followed by a digital message format that provides identification data. The 406 MHz system uses spacecraft-borne equipment to measure and store the Doppler-shifted frequency along with the satellite EPIRB digital data message and time of measurement. This information is transmitted in real time to an earth station called the Local User Terminal (LUT), which may be within the view of the satellite, as well as being stored for later transmission to other LUTs. In the real-time mode, the signal detection is limited to a mutual EPIRB-satellite-LUT circular visibility area of about 2500 km radius that moves with the satellite along its track. However, because of the stored-mode capability at 406 MHz, the need for this mutual EPIRB-satellite-LUT visibility is not essential, and the system is fully functional worldwide.
- 6.2.4 The LUT processes the Doppler-shifted signal and determines the location of the satellite EPIRB; then the LUT relays the position of the distress to a Mission Control Center (MCC) where the distress alert and location information is immediately forwarded to an appropriate maritime Rescue Coordination Center (RCC). The RCC dispatches Search and Rescue (SAR) forces.
- 6.2.5 The COSPAS-SARSAT System includes 36 LEOSAR LUT stations, 6 GEOSAR LUT stations and 19 Mission Control Centers that provide real-time as well as global-mode coverage for the Northern Hemisphere, while the Southern Hemisphere is presently served primarily by the global mode. Additional LUTs and MCCs are planned for installation in the near future both in the northern and southern hemispheres.

The addition of the GEOSAR Satellite system greatly improves the reaction time for a SAR event. This satellite system has no Doppler capabilities at 406 but will relay the distress alert to any of the LUT stations. When there is GPS data included in the distress message, SAR authorities instantly know where you are located. This speeds up the reaction time by not having to wait for one of the LEOSAR satellite's to come around.

- 6.2.6 Because most of the search and rescue forces presently are not equipped to home on the 406 MHz Satellite EPIRB signal, homing must be accomplished at 121.5 MHz.

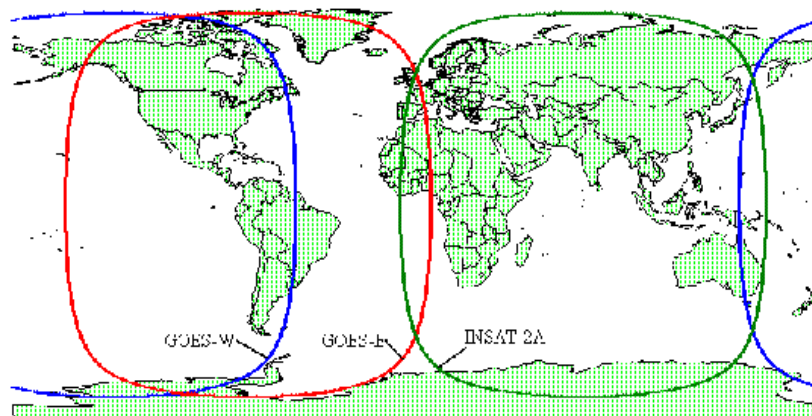

**SATELLITE COVERAGE**  
**Figure 1**

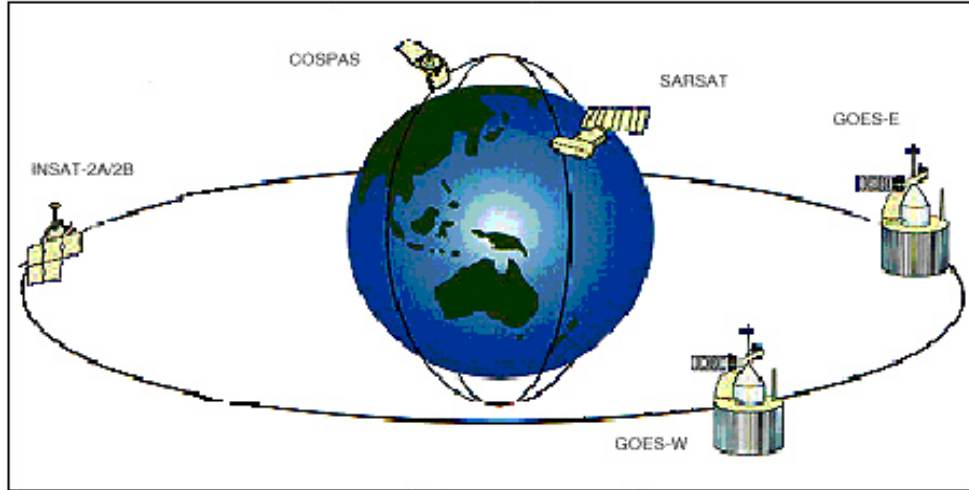

**GEOSAR SATELLITE ORBITS**  
**Figure 2**

**SECTION 7 - AUTHORIZATIONS**

7.1 The **GlobalFix™ 406 EPIRB** meets the requirements of Federal Communications Commission (FCC) Part 80 (Product No. 2742 Cat. I, 2744 Cat. II); and GMDSS (Product No. 2742) and MED 0735/2001

**7.2 Characteristics**

:

7.2.1 The **GlobalFix™ 406 EPIRB** is a floatable, battery operated unit. The beacon case, with its external antenna, is waterproof. The semiconductor circuits are mounted within the case assembly that also contains the battery power supply. A “Test/On” switch is installed on top of the beacon, along with a strobe light. The Cat. I beacon must be stored in its special mount, free of obstructions aboard a vessel for automatic float-off. The unit is self-buoyant and no external flotation devices are required.

### 7.3 Technical Data - GlobalFix™ 406

7.3.1 The **GlobalFix™ 406** EPIRB is available in two combinations. The following product codes define the options available to meet specific operational requirements:

Prod. No.	Model No.	Cat. I	Cat. II
2742	RLB-35	X	
2744	RLB-35		X

*Note: All models above conform to Class 1 Requirements (operations: -40°C to 55° C storage: -50°C to 70°C)*

#### Applicable Documents

RTCM	Standard for 406 MHz Satellite EPIRBs
COSPAS-SARSAT	Document C/S T.001 Oct. 99
FCC	Part 80 (Model No. RLB-35) and GMDSS (Prod.No. 2742)
MED	0735/2005



### 7.3.2 Specifications

#### 406 MHz Transmitter

Frequency	406 MHz
Frequency Stability	±2 parts per billion/100ms
Output Power	5 watts
Digital Message	
Format	Serialized <sup>1</sup>
Duration	520 ms
Rate	400 bps
Encoding	Biphase L
Modulation	±1.1 radians peak

<sup>1</sup> Leaves ACR with Serialized U.S. code but can be reprogrammed at a Service center to Maritime MMSI.

#### 121.5 MHz Transmitter

Frequency	121.5 MHz
Frequency Tolerance	±50 ppm
Output Power	25 mW PEP
Modulation	
Type	AM (3K20A3X)
Sweep Range	400 to 1200 Hz
Sweep Rate	3 Hz
Duty Cycle	37.5%

<u>Antenna</u>	
Frequency	406 & 121.500 MHz
Polarization	Vertical
VSWR	Less than 1.5/1

<u>Xenon Strobe</u>	
Light Color	White
Output Power	0.75 effective candela
Flash Rate	20—30 per minute

General/Environmental

Battery Life	
Operating	48 hours minimum
Replacement Interval	5 years

Size	
EPIRB less Antenna	9.0" (22.86 cm)
Antenna	7.5" (19.05 cm)
Material, EPIRB	High impact and UV resistant plastic
Color	Yellow
Weight	2.25 lbs.
Temperature Range	
Operating	Class I -40°C to +55°C
Stowage	Class I -50°C to +70°C

**7.3.3 Accessories**

Mounting Case Cat. I (Product No. 2742)

Construction	White High Impact and UV resistant HDPE
Size	6.5" x 17.1" (16.51 cm x 43.4 cm)
Release System	Hydrostatic with manual override

Hydrostatic Release Kits

No. 9367	<b>GlobalFix™ 406</b>
----------	-----------------------

Mounting Brackets (P/N 2744 Cat II.)

Construction	White High Impact and UV resistant plastic
Size	5.3" x 6.9" (13.5 cm x 17.5 cm)

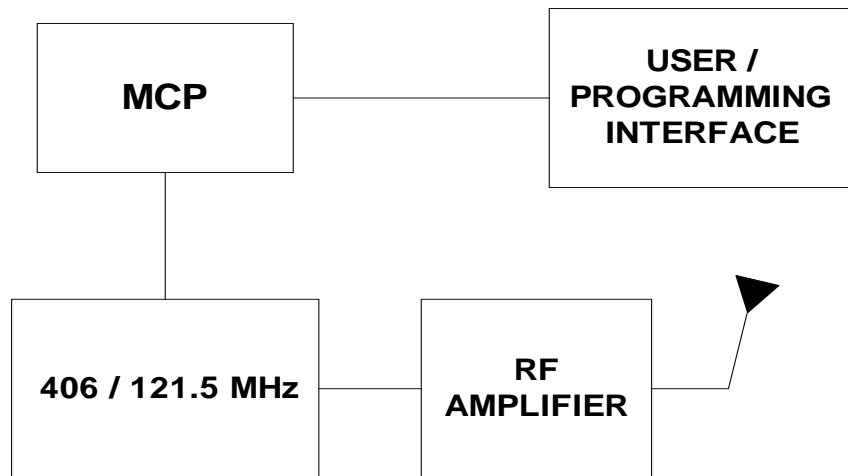

**EPIRB BLOCK DIAGRAM**  
**Figure 3**  
**(For Technical Reference Only)**

#### **7.4 Limited Warranty**

7.4.1 This product is warranted against factory defect in material and workmanship for a period of five years from date of purchase or receipt as a gift. During the warranty period ACR Electronics, Inc. will repair or, at its option, replace at no cost to you for labor, materials or return transportation, provided you obtain a Return Authorization from ACR Electronics, Inc., 5757 Ravenswood Road, Ft. Lauderdale, Fl. 33312-6645. To obtain a Return Authorization, call our Customer Service Department at (800) 432-0227. This warranty does not apply if the product has been damaged by accident or misuse, or as a result of service or modification by other than the factory.

Except as otherwise expressly stated in the previous paragraph, the COMPANY MAKES NO REPRESENTATION OR WARRANTY OF ANY KIND, EXPRESS OR IMPLIED, AS TO MERCHANTABILITY, FITNESS FOR A PARTICULAR PURPOSE, OR ANY OTHER MATTER WITH RESPECT TO THIS PRODUCT. The Company shall not be liable for, consequential or special damages.

In order to place the warranty in effect, the accompanying registration card must be returned to us within ten days of purchase.

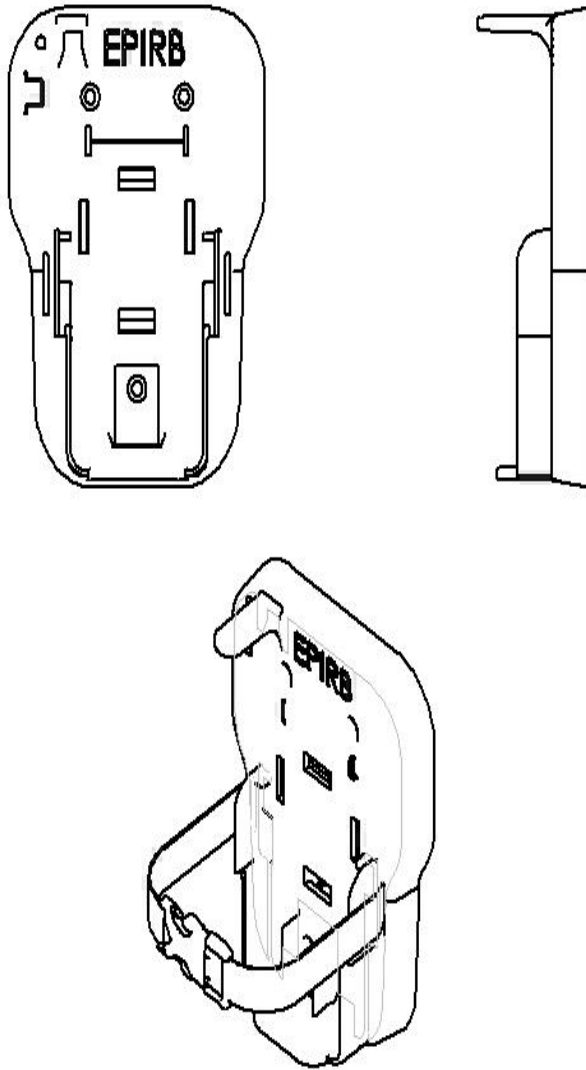

**UNIVERSAL LOW PRO 2 BRACKET**  
**Figure 4**



GLOBALFIX LABEL INSTRUCTION  
Figure 5

## **DECLARATION OF CONFORMITY**

We hereby declare that the following product is in conformity with EU Directive 96/98EC Marine Equipment Directive 29<sup>th</sup> Dec. 1996, modified by EU Commission Directive 98/85/EC dated 11<sup>th</sup> Nov. 1998

**Product** : Emergency Position Indicating Radio Beacon (EPIRB)  
ACR GlobalFix RLB-35 (Cat I & Cat II)

**Notified Body** : BSH Germany  
Registration No. BSH/6492/0039/01  
No. BSH 0735

**Type Examination Standard's** : ETS 300 066, IEC 60945, IEC 61097-2  
IMO Res. A.810 (19), COSPAS-SARSAT C/S T.001/007

**Manufacturer** : ACR Electronics Inc. Fort Lauderdale, Florida, USA

**EU Representative** : ACR Electronics Inc. (European Office)  
Lymington, Hampshire, UK.

**Signed on behalf of ACR Electronics Inc.**

Signed :  \_\_\_\_\_

**Name:** John Flood

**Title:** VP Engineering

**Date :** August 1, 2001