

central systems

Direct Expansion Split System A.C. Installation, Operation & Maintenance

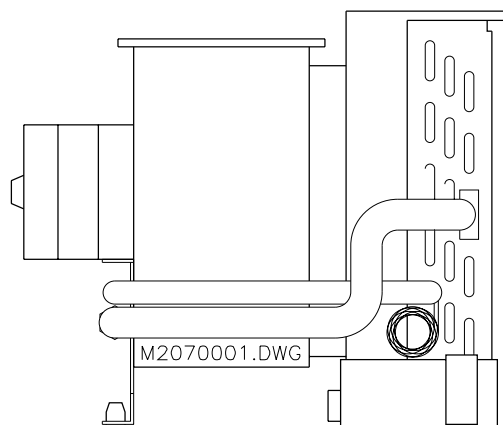
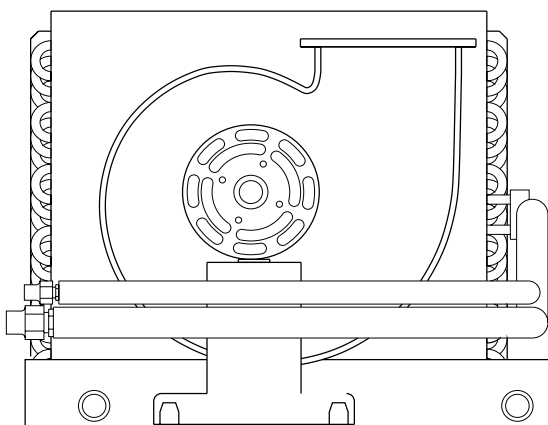
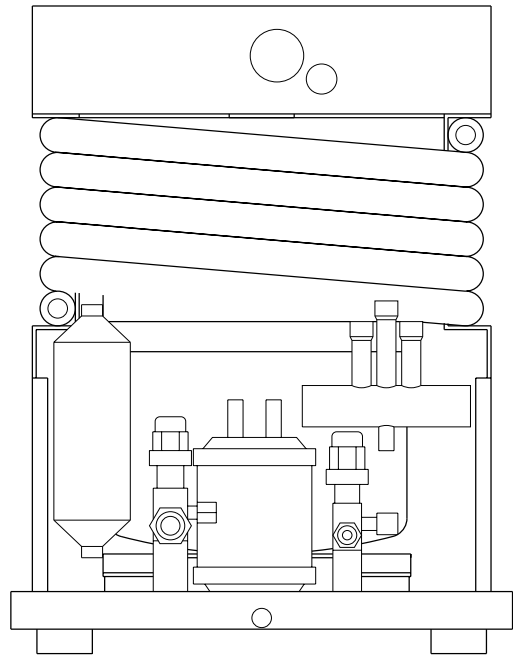
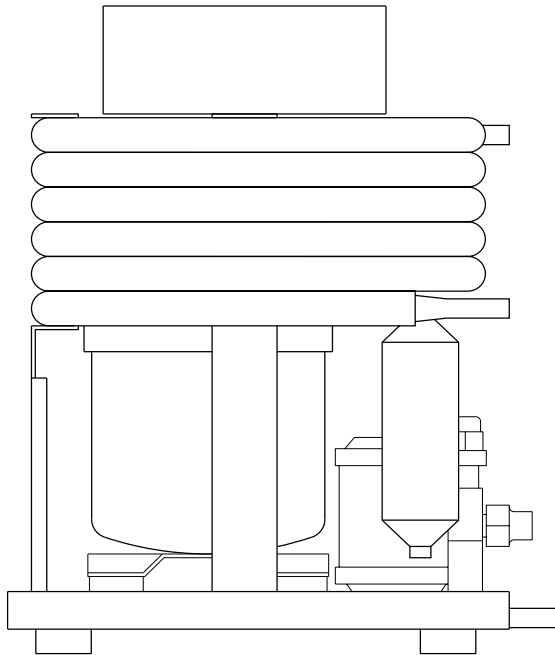

PREFACE

Congratulations on the purchase of your Marine Air Systems' CENTRAL SYSTEMS air conditioner. No matter which of the following features was the reason for your purchase of this air conditioner, we are sure it will meet your needs and will give you many years of efficient and trouble free use. The CENTRAL SYSTEMS units are split-system direct expansion air conditioners designed for marine applications incorporating the following features:

- High efficiency compressors provide significant reductions in amperage draw
- Cupronickel condenser coil enclosed in a copper shell resists corrosion
- Two sets of vibration isolators for quieter performance
- Pre-charged and pre-wired systems for easy installation
- Charge Guard® ensures environmental protection and refrigeration system integrity
- Rotatable insulated blower assemblies on air handlers
- Evaporator coils with raised lance fins and rifled tubing for maximum efficiency
- Air handlers have insulated drain pans with multiple condensate drain locations

The PASSPORT®II microprocessor based digital controller, optional with this unit, offers the most technologically advanced design specifically made for the unique requirements of marine air conditioning. The controller has been designed with flexibility and the following "user friendly" features customers require for their applications:

- Non-volatile memory
- Low voltage display panel
- Face plate air sensor for accurate temperature control
- LED cabin temperature displayed in Fahrenheit or Celsius
- Multiple fan speed selections with adjustable high and low limits
- User selected programs for optimum control
- Optional outside air temperature sensor
- Compressor fail-safe pressure protection
- Compressor start staging delay for multiple a/c systems
- Moisture mode cycle for humidity control
- De-Icing feature to prevent evaporator icing
- Blank display for nighttime operation

This manual is intended to provide the information necessary to ensure proper installation, operation, and maintenance of the unit. Improper installation or misunderstood operating procedures can result in unsatisfactory performance and/or premature failure of these units, so before proceeding ***please read this manual completely.***

This unit is covered under the existing Marine Air Systems' warranty policy contained in this manual. In the interest of product improvement, Marine Air Systems' specifications and design are subject to change without prior notice.

MARINE AIR SYSTEMS

Marine Air Systems (MAS) is a product of Taylor Made Environmental, Inc (TME). TME is a recognized leader in the design and manufacture of high-performance comfort control systems, refrigeration products and battery charging products for demanding environments, including commercial and recreational marine craft, vehicles and other applications. We offer an unparalleled scope of products, dealer networks, applications support, engineering resources and production capabilities throughout the world. Our team has many years of experience in the design, manufacture, application and support of our products. Our practical experience and design capability allows our application engineers and sales representatives to offer optimum solutions for your environmental control requirements. Product lines also include well known Cruisair®, Grunert®, and Sentry™. TME is a member of the Taylor Made Group.

TABLE OF CONTENTS

INSTALLATION

Unpacking and Inspection	4
Clean Air Act Amendments of 1990	4
How It Works	4
Safety Considerations	5
Refrigerant Connection Sizes	5
Placement of System (Tools Required)	6
Mounting the Condensing Unit	7
Mounting the Air Handler	7
Condensate Drain Lines	7
Copper Line-Sets	7
Single Thickness Flare Procedure	8
Leak Checking of the System	8
Pressure Test	8
Leak Check	9
Evacuating and Charging the System	9
Evacuation	9
Charging	10
Refrigerant Temperature & Pressure	11
Insulating the Line-Set	11
The Heating Cycle	11
Central Systems: 6k-16k	12
Multi Ton Systems: 24k-60k	12
Refrigerant System Schematics	13
Supply & Return Air Grilles	14
Ducting	14
Seawater Pump and Plumbing	15
Electrical Connections, Grounding and Bonding	16
3 Phase Notice	16
Central Systems Wiring Diagrams	17-19
Manual Control Panel (MCP) Installation	20
Slave Fan Speed Control	21
Passport II Display Panel Installation	21
Installation Checklist (review prior to installation)	22

OPERATION

Manual Control Panel (MCP) Operation	20
Quick Start Operations Checklist	22
Passport II Control	23
Modes of Operation	23
Programming the Passport II	24
Programmable Parameters	25
Programming Notes	27
Troubleshooting Guidelines	28-31

MAINTENANCE

Seawater System, Return Air Filters, Winterization	32
Manufacturers Limited Warranty Agreement	33
Domestic Distributors listing	35

REVISION HISTORY:

Original Print: July 1998 - Revised: 4/99, 5/99, 6/99, 11/01

INSTALLATION

UNPACKING AND INSPECTION

When the equipment is received, all items should be carefully checked against the packing list to ensure all cartons have been received. Move units in the normal “up” orientation as indicated by the arrows on each carton. Examine cartons for shipping damage, removing the units from the cartons if necessary. If the unit is damaged, the carrier should make the proper notation on the delivery receipt acknowledging the damage.

CAUTION: When unpacking and installing the 2 knob control, care must be taken not to kink or break the copper cap tube when uncoiling the sensing bulb. The cap tube is hollow and kinking or sharp bends will inhibit system operation.

CLEAN AIR ACT AMENDMENTS OF 1990 [TITLE VI - SECTION 608(C-1)]

“Effective July 1, 1992, it shall be unlawful for any person, in the course of maintaining, servicing, repairing, or disposing of an appliance or industrial process refrigeration, to knowingly vent or otherwise knowingly release or dispose of any Class I or Class II** substance used as a refrigerant in such appliance (or industrial process refrigeration) in a manner which permits such substance to enter the environment. De minimis releases associated with good faith attempts to recapture and recycle or safely dispose of any such substances shall not be subject to the prohibition set forth in the proceeding sentence.”*

**Class I substances include CFC-12*

***Class II substances include HCFC-22*

HOW IT WORKS

Your split-system air conditioner consists of four main components divided into two units and a refrigerant gas circulating through the system. The air handler consists of a blower (fan) and an evaporator coil, and the condensing unit consists of a compressor and a condenser coil. A copper line set connects the air handler(s) and the condensing unit to each other. The air handler blower draws warm humid cabin air across the fins on the evaporator where the heat from the air is transferred to the refrigerant in the evaporator coil. (The moisture in the air is captured on the evaporator coil by forming condensation as the air is cooled.) As the refrigerant evaporates from a liquid into a gas it absorbs the heat from the cabin air. The compressor then compresses the refrigerant gas and pumps it through the outer tube in the condenser coil. The seawater pump circulates cool seawater through the inner tube in the condenser coil; this cools the refrigerant and condenses it into a liquid. The heat from the refrigerant is exchanged to the seawater and discharged overboard. The liquid refrigerant is then passed through the evaporator coil and the cycle repeats. Removing heat and moisture from the cabin air lowers its temperature and humidity levels. The conditioned air is blown through the ducting and out the supply air grille(s).

For reverse cycle heating, the refrigerant flows in the opposite direction through the reversing valve. Heat is transferred from the seawater in the condenser coil to the refrigerant and then to the air blowing through the evaporator into the cabin. For a detailed explanation, see The Heating Cycle section of this manual.

Seawater temperature will directly affect the a/c unit's, if revers cycle, efficiency. This a/c unit can effectively cool your boat in water temperatures up to 90°F and heat in water as low as 40°F.

SAFETY CONSIDERATIONS

Never install your air conditioner in the bilge or engine room areas. Insure that the selected location is sealed from direct access to bilge and/or engine room vapors. Do not terminate condensate drain line within three (3) feet of any outlet of engine or generator exhaust systems, nor in a compartment housing an engine or generator, nor in a bilge, unless the drain is connected properly to a sealed condensate or shower sump pump.

Installation and servicing of this system can be hazardous due to system pressure and electrical components. When working on this equipment, always observe precautions described in the literature, tags and labels attached to the unit. Follow all safety codes. Wear safety glasses and work gloves and place a fire extinguisher close to the work area. The following is a summary of the labels on the unit:

! DANGER ELECTRICAL SHOCK HAZARD. DISCONNECT VOLTAGE AT MAIN PANEL OR POWER SOURCE BEFORE OPENING ANY COVER. FAILURE TO COMPLY MAY RESULT IN INJURY OR DEATH.

! WARNING THIS COMPONENT DOES NOT MEET FEDERAL REQUIREMENTS FOR IGNITION PROTECTION. DO NOT INSTALL IN SPACES CONTAINING GASOLINE ENGINES, TANKS, LPG/CPG CYLINDERS, REGULATORS, VALVES OR FUEL LINE FITTINGS. FAILURE TO COMPLY MAY RESULT IN INJURY OR DEATH

NOTICE THIS COMPONENT IS CHARGED WITH HYDROCHLOROFLUOROCARBON (HCFC) REFRIGERANT R22. EFFECTIVE JULY 1, 1992 IT SHALL BE UNLAWFUL FOR ANY PERSON TO KNOWINGLY VENT OR OTHERWISE KNOWINGLY RELEASE ANY CLASS 1 (CFC) OR CLASS 2 (HCFC) SUBSTANCE AS A REFRIGERANT IN A MANNER WHICH PERMITS SUCH SUBSTANCE TO ENTER THE ATMOSPHERE PER THE CLEAN AIR ACT OF 1990. PUBLIC LAW 101-549 TITLE IV SECTION 608-C. FAILURE TO COMPLY MAY RESULT IN SEVERE PENALTIES, INCLUDING FINES AND IMPRISONMENT.

! WARNING TO MINIMIZE THE HAZARD OF ELECTRICAL SHOCK AND PERSONAL INJURY, THIS COMPONENT MUST BE EFFECTIVELY GROUNDED. REFER TO THE INSTALLATION GUIDELINES FOR FURTHER INFORMATION.

CAUTION! HIGH COMPRESSOR TRMPERATURE IS NORMAL **DO NOT TOUCH.**

REFRIGERANT CONNECTION SIZES

The Central System condensing units and Multi Ton condensing units are connected to their respective evaporators (air handlers) by copper line sets. Copper line sets come standard with flare fittings, quick disconnect fittings are available upon request. The table below shows connection sizes for all units.

Condensing Unit Size	6/9/12	16	24/30	36/48	60
Evaporator Unit Size	4/6/9/12	16	24	36/48	N/A
Discharge Connection Size	1/4"	1/4"	3/8"	3/8"	5/8"
Suction Connection Size	3/8"	1/2"	5/8"	3/4"	7/8"

PLACEMENT OF THE SYSTEM

Selecting a good location for your air conditioner is the most important part of your preparations. Be sure to consider the size of the area you are cooling, the air distribution needs, and the size of the unit you have chosen. Keeping in mind that cool air has a tendency to fall, it is highly recommended that you locate the supply air grille as high as possible in the cabin. Plan all connections which must be made prior to starting installation, including ducting, grilles, copper line-set, condensate drain, cooling water in and out, electrical power connections, location of control panel, and seawater pump placement and plumbing, to assure easy access for installation and servicing. See diagram below.

Tools required

- standard tool box
- service wrench
- flaring tool
- refrigerant gauge manifold
- refrigerant tank
- nitrogen tank
- vacuum pump
- charging cylinder
- micron gauge
- electronic leak detector
- drill/hole saw
- jig saw
- insulated tape
- duct tape
- electrical tape
- teflon tape
- Beding compound to seal thru hull fittings
- Hardware to secure unit, pump, strainer, grilles & control panel

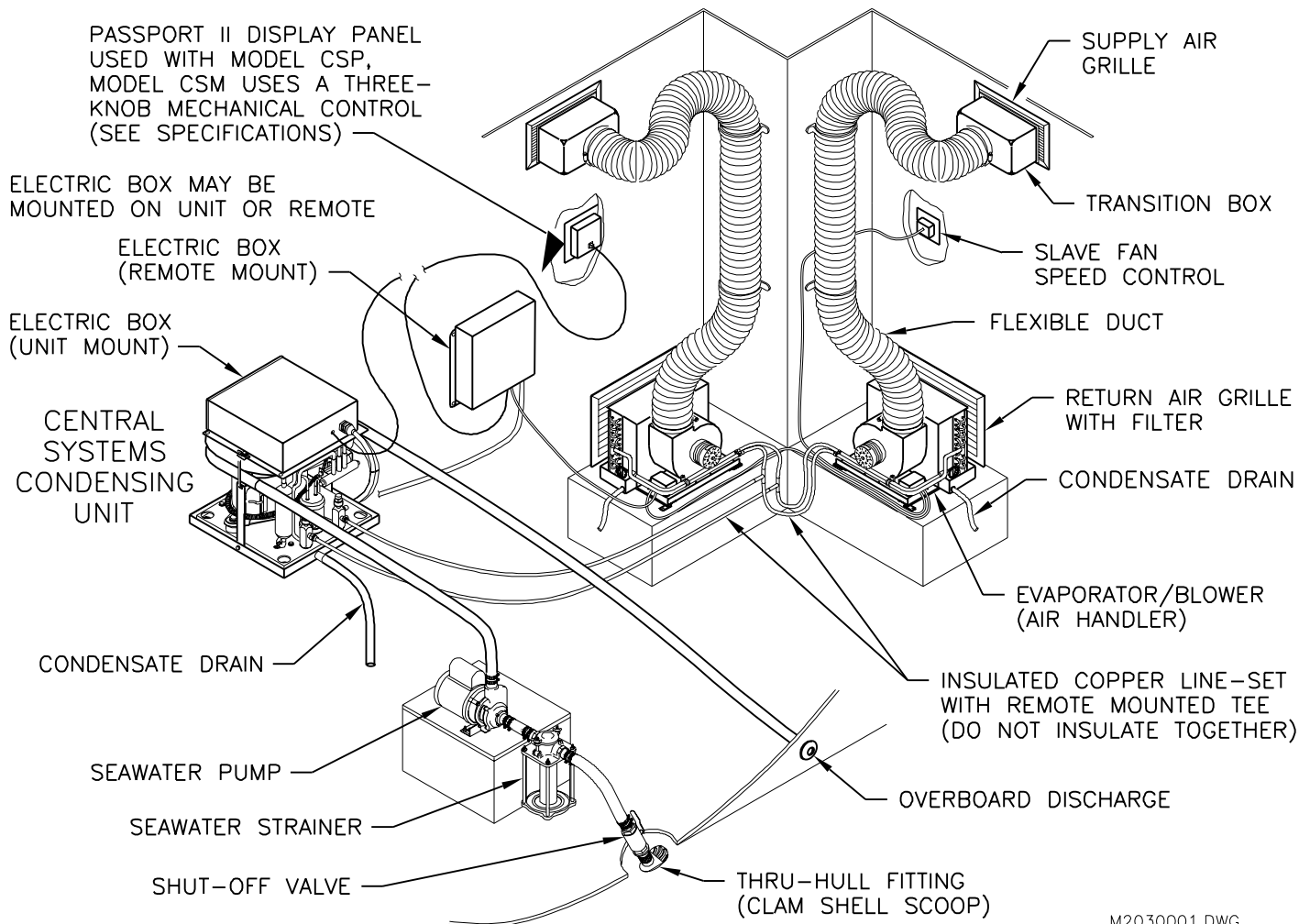

M2030001.DWG

MOUNTING THE CONDENSING UNIT

The location of the condensing unit should be dry and accessible for service, and provide the most direct routing of refrigerant line sets relative to the air handler location(s). The condensing unit should be installed lower than the air handlers so that the refrigerant oil returns to the compressor. The vibration isolated condensing unit should be secured to a horizontal shelf that is designed for the weight of the unit and torsion loads from the vessel's movement. The multi ton unit's electrical box may be remotely mounted to a bulkhead or sturdy frame using the hardware provided. However, the electrical box does contain a position sensitive relay. The box can be remote mounted in the same position as it sits on the condensing unit or, if another position is desired, open the box and rotate the relay bracket to the proper position. The 6-16K unit's electrical box must remain mounted on the unit. The condensing unit should be mounted with the drain line pointing aft; the base pan can be rotated to accomplish this configuration.

MOUNTING THE AIR HANDLER

The air handler should be installed as low as possible (such as under a V-berth, dinette seat or bottom of a locker) and the supply air should be ducted as high as possible. This type of installation creates an ideal air flow condition and will prevent short cycling. Securely fasten the air handler to a solid, level surface using the two mounting clips on the drain pan and the vibration isolators on the blower bracket with the four screws provided. Be sure that the blower motor has at least one inch (1") of air space in front of it to provide proper ventilation. Rotate the blower, if necessary, to provide the most direct route of ducting to the supply air grille(s) or transition boxes. To rotate the blower, remove the two self-tapping screws from the blower ring (between the blower housing and the evaporator shroud) and remove the two self-tapping screws from the blower mounting bracket. Rotate the blower to the desired position and replace the screws.

CONDENSATE DRAIN LINES

The air handler condensate drain pan has two ½" FPT drain fittings. Screw the PVC hose barbs provided into the drain fittings using teflon tape for a watertight seal. The two drains may be teed together, providing there is a minimum drop of two inches (2") from the drain pan to the tee fitting. The condensing unit has a 5/8" O.D. drain pipe on its condensate drain pan. Use 5/8" hose and stainless steel hose clamps on all drain lines. During conditions of high humidity, condensate may be produced at a rate of up to two gallons per hour. With this in mind, it is important to route condensate drains downward to a sump pump. Do not route air handler condensate drain lines directly to the bilge (see warning below). Condensing unit drain line may terminate in the bilge because the condensing unit does not handle air. After the condensate drain installation is complete, test the installation by pouring a quart of water into the pan and checking for good flow. Occasionally pour a bleach and water solution into the pan to clean any algae or sediment out of the lines.

WARNING: Do not terminate air handler condensate drain lines within three (3) feet of any outlet of engine exhaust systems, nor in a compartment housing an engine or generator, nor in a bilge, unless the drain is properly connected to a sealed condensate or shower sump pump. Exhaust and/or bilge fumes can travel up a drain line and mix with the return air blowing into living areas.

COPPER LINE-SETS

Refrigeration grade tubing is required to connect the refrigerant circuit from the evaporator to the condensing unit. Refrigerant tubing is normally soft drawn and nitrogen purged. All refrigerant lines should be capped to protect against moisture and dust infiltration until the flare connections are made to the

evaporator and condenser base valves. Extreme care must be taken not to crush or kink any portion of either line set. Use proper tools for line bending, avoiding sharp bends or kinks. Any kinked or crushed section must be replaced. Any excess tubing should be coiled in a horizontal plane and secured to prevent vibration. There should be no vertical loops (oil traps) in the copper lines. Keep tubing clear of bilge water, steering cables and similar obstructions. Secure tubing approximately every 12" to prevent vibration and/or chafing. **DO NOT CRUSH INSULATION.**

When using multiple evaporators, ensure that the dual, triple or quad fittings are sized correctly to allow correct size tubing to be connected to air handler fittings and provide proper refrigerant flow to and from each air handler.

SINGLE THICKNESS FLARE PROCEDURE

The liquid and the suction line are to be flared and connected to the base mounted valves. Refrigeration flares must be perfect!!! Unsatisfactory installations result from faulty flare connections. **CHECK YOUR FLARING TOOL.** Ensure that the cone is clean, if the cone is scratched or damaged, do not attempt to make refrigeration quality flares with it. Use a refrigeration flaring tool, not a plumbing tool. See next section for proper flaring procedure.

Use a typical flaring tool consisting of Flare Block and on screw driven flaring cone. Cut and debur copper tubing—being careful not to allow any contaminants to fall inside the tubing. Slide flaring nut onto tubing before making the flare. Insert end of copper tubing into matching size block hole and push end through to line up with height gauge on flare yoke. Tighten clamp to secure tubing. Put a drop of refrigeration grade oil on the flaring cone. Tighten 1/2 turn then back off 1/4 turn. Repeat tightening and loosening procedure until flare is fully formed. Some service technicians make the flare using one continuous motion of the flaring tool. This technique can work-harden the tubing and make it more likely to split. Do not over-tighten the spinning tool because this will thin the wall of the tubing at the flare and weaken it.

Check each flare for splits and burrs. The flare nut should fit around the flare easily without contacting threads when nut is pulled to the end. Be certain that flares are expanded to provide a complete seat on the fittings. If the flare is over expanded and touching the flare nut threads, do not attempt to draw it up, remake the flare. The flare should almost fill the flare nut but not touch the threads. **IMPORTANT:** Add a drop of refrigerant oil to both the inside and outside of the flare to prevent galling (twisting and chafing) the copper flare. Hold the fitting with a backup wrench and turn only the flare nut when tightening a refrigeration connection. Leave enough length in the tubing so that the connection may be cut off and remade if necessary.

LEAK CHECKING OF THE SYSTEM

Once the refrigerant line-set connections are made a pressure test and leak check of the system must be performed. **NOTE!** The base valves on the unit are shipped in the Front Seated Position to retain the refrigerant in the condensing unit. These valves must not be opened until the system is ready for operation.

PRESSURE TEST

- 1) Connect the high and low side hoses of your gauge manifold to the condenser base valves.
- 2) Connect the charging hose to your **Nitrogen** tank and set the regulator to a maximum pressure of 300psig. **CAUTION!** Pressurizing the system above 120psig will put the needle of the low side gauge in the retard section and can damage the gauge. Prior to pressurizing the system it is recommended that the hose for the low side gauge be removed and the service port capped tightly to

retain the pressure. Compressed air or CO₂ should not be used as they can add moisture and other contaminants to the system! Refrigerant pressure varies with temperature and should not be used unless needed for electronic leak detection. **CAUTION!** Exceeding 300psig is dangerous due to the possibility of rupturing hoses or line-set connections due to poor flares.

- 3) Once the regulator on the nitrogen tank is set, open the tank valve. Crack open the high side valve on the gauge manifold and the low side valve if used. The needle(s) will rise as the pressure enters the line set and evaporator(s). Once the point of the predetermined pressure has been reached, close the gauge valve(s). Monitor the gauge reading(s) after the pressure has stabilized (should be less than a minute). The pressure should be left in the system for a minimum of 15 minutes. The gauge reading should remain constant, if the gauge pressure drops then there is a leak in the system. Refer to the leak check section to determine the location of the leak(s). If the gauge pressure holds then proceed to the evacuation and charging sections. **NOTE!** It is sometimes assumed that all leaks must be on the equipment when in reality they can also occur on the gauge manifold and hoses. Before use, inspect the fittings on the manifold for tightness and if the hoses are damaged or gaskets worn replace them.

LEAK CHECK

- 1) A rapid drop in gauge pressure indicates a large leak or several small ones. Usually these can be detected by a hissing sound at the leaking fitting or felt by placing your hand around the fitting. **NOTE!** If the pipe insulation is encasing a leaking fitting the escaping nitrogen can be forced down the insulation to a remote location and give a false leak indication.
- 2) Small leaks, indicated by a slow drop in gauge pressure, can be difficult to locate.
 - a) A soap solution can be applied to the fittings. Bubbles will indicate leaks. **CAUTION!** Care must be taken to ensure soap solution does not ingress into a leaking fitting(s) and contaminate the system. After you have finished leak checking, clean off soap solution.
 - b) If the leak cannot be detected by soap solution, an electronic leak detector should be used. For this procedure a small quantity of refrigerant needs to be added to the nitrogen in the system.
- 3) The above procedures are to be repeated until all leaks are found and repaired. Once the system holds pressure, the nitrogen or nitrogen/refrigerant mixture is to be purged from the system. The line set and evaporator(s) are now ready for evacuation. **CAUTION!** When purging high-pressure nitrogen from the system wear safety glasses and gloves. Secure the hose end to prevent injury to personnel or property damage. Do not point the hose towards personnel or property. To prevent inhalation, the nitrogen should not be expelled into a confined space where personnel are working; the work area should be well ventilated. **If the nitrogen is mixed with refrigerant, contact with an open flame or hot surface could create PHOSGENE GAS, which can cause respiratory problems or death.**

EVACUATING AND CHARGING THE SYSTEM

WARNING! If skin or eyes come into contact with refrigerant, flush thoroughly with water. Skin contact with refrigerant can cause frostbite. Wear gloves at all times.

EVACUATION

Connect the center hose from the gauge manifold to the vacuum pump. Leave the high side hose connected to its base valve. If the low side hose is not connected to its respective base valve then do so. A micron gauge should be installed in the high or low side hose with an isolation valve (some gauge manifolds have an additional vacuum/charging port for this purpose). It should be noted that the base valves are front seated and should not be cracked open at this point. Open both hand valves on the gauge manifold as far as they will go (turn valves fully CCW). Open the isolation valve on the micron gauge. Start the vacuum pump, allow it to operate for half an hour and

then close the gauge manifold hand valves (CW). Observe the gauges for 10 minutes to see if the system holds its vacuum. If a leak is indicated then follow the leak check procedure above. Be sure to shut off the isolation valve for the micron gauge before pressurizing the system. If no leak is indicated, open (CCW) the hand valves on your gauge manifold and allow the vacuum pump to continue evacuating the system. When a vacuum of 500 microns (29.99in.Hg) is achieved, close both gauge manifold hand valves but do not close the isolation valve to the micron gauge. At this point the vacuum pump can be turned off. If the pump is turned off before the gauge manifold hand valves are closed the vacuum will be lost and the evacuation procedure will have to be repeated. Monitor the micron gauge again to see if a leak is indicated. If the system holds its integrity then the isolation valve for the micron gauge can be closed and the system is ready for charging.

CHARGING

The base valves can now be opened starting with the liquid line valve first. Rotate the valve stem counter clockwise to the mid-seated position (cracked). The pressure will rise quickly on the high side gauge followed by a steady rise on the low side gauge as the refrigerant passes through the metering device. Open the suction side base valve to the cracked position also. This will allow the system pressures to be monitored when the unit is running and allow for the addition of refrigerant if necessary. The charge supplied with the condensing unit is sufficient for the condensing unit and the evaporator. The following chart shows the refrigerant charge of each unit as shipped from the factory.

	CS-6K	CS-9K	CS-12K	CS-16K	CS-24K	CS-30K	CS-36K	CS-48K	CS-60K
Oz	20	21	24	24	46	50	56	76	80
Kg	0.57	0.60	0.68	0.68	1.30	1.42	1.59	2.15	2.27

Evaporators with quick disconnect fittings are charged with one ounce (1 oz) of refrigerant (approximately 75 psig) as a holding charge. Line sets with quick disconnect fittings are factory charged with the amount of refrigerant denoted below in ounces per foot (oz/ft). One foot of line set includes both the liquid and suction lines (see example below chart). Use the chart below to charge line sets constructed in the field. Use this formula to convert ounces to kilograms: 1 oz = 0.0283 kg.

LINE SIZE	1/4" suction	3/8" suction	1/2" suction	5/8" suction	3/4" suction
1/4" liquid	0.23 oz/ft	0.24 oz/ft	0.25 oz/ft	0.26 oz/ft	0.28 oz/ft
3/8" liquid	-	0.64 oz/ft	0.65 oz/ft	0.67 oz/ft	0.68 oz/ft
1/2" liquid	-	-	1.23 oz/ft	1.24 oz/ft	1.26 oz/ft
5/8" liquid	-	-	-	2.02 oz/ft	2.03 oz/ft
3/4" liquid	-	-	-	-	2.76 oz/ft

EXAMPLE: If a line set is twenty feet (20' long with a 1/4" liquid line and a 3/8" suction line then multiply 20 times **0.24** which equals 4.8 oz of refrigerant in the line set.

- If it is necessary to add refrigerant, connect the center hose from the gauge manifold to the charging cylinder. The cylinder valve should be opened and the hose purged of air. Refrigerant should be added through the low side of the gauge manifold in the form of vapor. However, in certain circumstances it may need to be added as a liquid. If so, it should still be added through the low side but in small amounts at any one time to prevent slugging the compressor. Once the system is charged, the valve on the charging cylinder can be closed but do not remove the hose. The liquid line base valve should now be turned fully counter clockwise (back-seated). Open both gauge manifold valves to allow the residual liquid/vapor in the hoses to return into the suction side. Close the gauge valves and back seat the suction base valve. The hoses can now be removed from the charging cylinder and unit. Put the protective caps back on the service valves.

Special air handlers are used for multiple evaporator applications. Air handler/evaporators used with multi ton condensing units (24K-60K BTU) are equipped with a check valve and either a thermostatic expansion valve (TXV) (24K) or cap tube (6-16K) assembly. These units have a suffix of "M" in the model number to indicate for multi ton use only.

When using two different size air handler/evaporators with a smaller condensing unit (9K-16K BTU), at least one air handler (usually the smaller one) should have a direct expansion (DEX) valve installed as indicated by “DX” in the model number. This valve is adjustable and will allow the system to be balanced. When balancing a multiple evaporator system, adjust the DEX valve on one evaporator until the other evaporator loads up. Turning the adjustment screw clockwise will open the valve allowing more refrigerant to flow. Turning the screw counterclockwise (ccw) will close the valve allowing less refrigerant to flow. NOTE: With the adjustment screw turned fully ccw the valve is still partially open.

REFRIGERANT TEMPERATURE & PRESSURE

Calculating the high side and low side pressures is difficult due to the variables involved. The high side (liquid line) pressure on a properly operating water-cooled unit is determined by the temperature of the seawater, water flow and how clean the condenser coil is. The low side (suction line) pressure is affected by fan speed, static pressure, and wet and dry bulb readings. For this reason the refrigerant charge should be properly measured into the system for optimum operation (see previous charts). The following chart should be used as a reference to monitor performance **in cool mode** and should not be used to charge the system.

Water Temperature	40°F	50°F	60°F	70°F	80°F	90°F
Head Pressure Range	144-176	153-187	162-198	180-220	198-242	220-270
Back Pressure Range	56-68	59-73	63-77	68-82	70-86	76-90

INSULATING THE LINE-SETS

- 1) Use ¾” thick closed cell type tube insulation with an inside diameter equal to pipe size. Place dust caps on both ends of pipe. Slide the tube insulation on each pipe prior to making connections.
- 2) After making the connections, push the tube insulation flush against the fitting. Trim if necessary to ensure a smooth application with no air pockets.
- 3) Do not seal insulation until after checking for leaks.
- 4) Pipe insulation joints should be glued, not taped. There must be no air pockets between the pipe and the insulation. **All insulation must be airtight to prevent condensation forming on pipes.**
- 5) If the tube insulation is installed after the refrigerant circuit is connected, proceed as follows:
 - Use pre-slit insulation or cut existing tube insulation and wrap around pipe.
 - Apply insulation adhesive thoroughly along both cut edges.
 - Press the glued edges back together making sure a proper bond is made with no openings, gaps or air pockets. Do not use wire ties to hold insulation around pipe in lieu of adhesive.
- 6) Tie wraps, wire ties or zip ties should not be used to secure insulation. Using these will compress the insulation and cause poor performance leading to condensation drips and damage to the vessel.
- 7) Use insulation tape provided to wrap the flare nut and base valve connections at both ends of each the line set. There should be no exposed copper or brass on the line set.
- 8) Do not insulate both lines together.**
- 9) Insulate the suction line only on a multi ton condensing unit system using models CS24-CS60.
- 10) Insulate the suction and liquid lines on a 6K-16K condensing unit system using models CS6-CS16.

THE HEATING CYCLE

MULTITON SYSTEMS WARNING! Care should be taken when attaching the low side of a gauge manifold in the heat cycle. On multi ton units, the suction line and base valve in the cooling mode become the

hot gas discharge line in heating mode. High-pressure refrigerant can retard and damage a low side gauge. An additional suction side service port is provided on the compressor shell and should be used for all suction pressure readings in the heating mode.

In the following sections the liquid receiver and suction accumulator will not be mentioned; this is to simplify the description of system operation. On all systems and in both modes of operation the configuration of the discharge and suction lines between the reversing valve and compressor remain the same.

CENTRAL SYSTEMS: 6K - 16K

In the **cooling mode** the reversing valve **is not** energized. Hot high-pressure gas is discharged from the compressor through the reversing valve to the water-cooled condenser coil. There the hot gas gives up heat to the cooler water circulating through the coil. The heated water is then discharged overboard. As the gas is cooled it condenses into a liquid. It is then fed to the metering device on the evaporator, which in this case is a capillary tube. The capillary tube is the transition point of the low and high side of the system and regulates the flow of liquid refrigerant into the evaporator. As the liquid travels through the evaporator tubing it absorbs heat from the air passing through the finned coil. This causes the liquid refrigerant to boil off into a vapor. The low-pressure vapor is then returned to the compressor via the suction line and then the reversing valve.

In the **heating mode** the reversing valve **is** energized. The plunger in the valve body moves, changing the direction of the refrigerant flow. The suction line becomes the hot gas discharge line. The hot gas line to the condenser now becomes the suction line. The hot gas flows to the air-cooled evaporator that is now the condenser. The cool air passing across the finned coil absorbs the heat from the refrigerant and warming the air as it is returned into the cabin. As the refrigerant gives up heat it again turns into a liquid. This is fed back through the capillary tubing into the liquid line and starts to boil off. The refrigerant passes through the condenser coil, which is now part of the low side evaporative circuit. Heat is absorbed from the water as it passes through the coil and the refrigerant boils off into a vapor. The vapor returns to the compressor via the reversing valve. The high side gauge should be moved to the other base valve to obtain a high side reading.

MULTITON SYSTEMS: 24K - 60K

In the **cooling mode** the multi ton systems operate in much the same way as the smaller central systems. There is however a significant component configuration change. On the condensing unit there is a TXV (thermostatic expansion valve), which is the metering device, and check valve assembly located between the condenser coil and liquid line base valve. In the cooling mode the refrigerant flows through the condensing unit's check valve, bypassing the TXV. The evaporator coil also has a metering device and check valve combination. Refrigerant cannot flow through this check valve in cool mode and therefore is injected into the evaporator through the metering device. This metering device can either be a TXV or a capillary tube, depending on the evaporator capacity. 24K evaporator/blowers have a TXV and 6-16K units have a capillary tube.

In the **heating mode** the reversing valve **is** energized. Again the plunger in the valve body moves, changing the direction of the refrigerant flow. What was initially the suction line between the condenser and the evaporator is now the hot gas discharge line. The hot gas line to the condenser coil from the reversing valve becomes the suction line. The hot gas flows to the air-cooled evaporator, which is now the condenser. The cool air passing across the finned coil now absorbs the heat from the refrigerant and the warmed air passes into the cabin. As the refrigerant gives up heat, it turns into a liquid. The liquid refrigerant bypasses the metering device via the check valve assembly and is fed into the liquid line. The

CENTRAL SYSTEMS REFRIGERANT SYSTEM SCHEMATICS

CS 6-16 IN COOL MODE

DISCHARGE SIDE IS HIGH PRESSURE HOT GAS
LIQUID SIDE IS HIGH PRESSURE LIQUID
SUCTION SIDE IS LOW PRESSURE COOL GAS.
RV = REVERSING VALVE IS NOT ENERGIZED
CAP = CAPILLARY TUBE (METERING DEVICE)

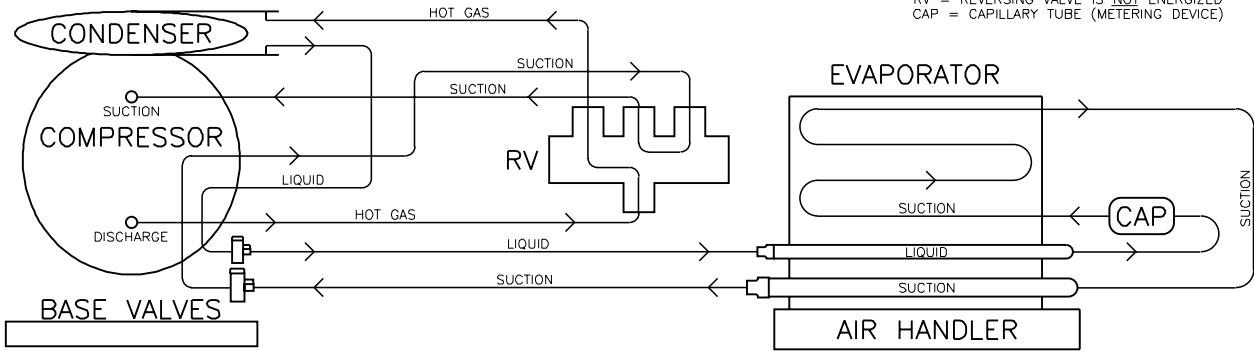

CS 6-16 IN HEAT MODE

DISCHARGE SIDE IS HIGH PRESSURE HOT GAS
LIQUID SIDE IS HIGH PRESSURE LIQUID
SUCTION SIDE IS LOW PRESSURE COOL GAS.
RV = REVERSING VALVE IS ENERGIZED IN HEAT
CAP = CAPILLARY TUBE (METERING DEVICE)

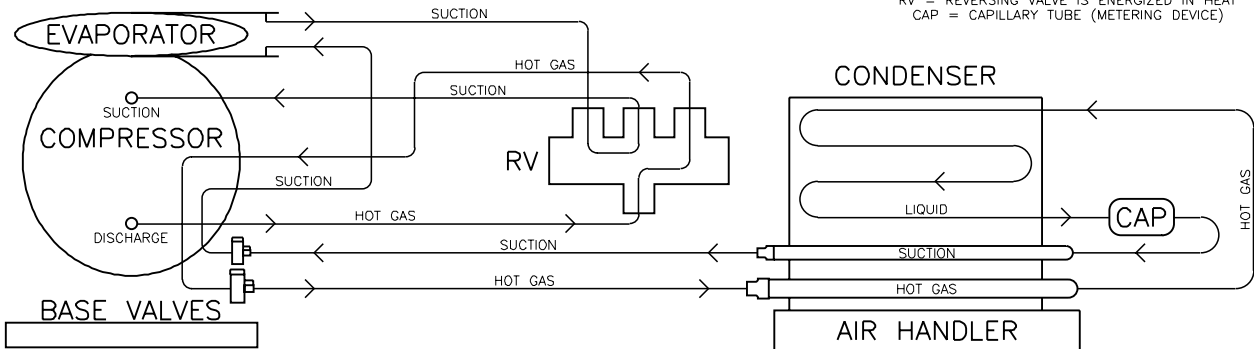

CS 24-60 MULTI TON IN COOL MODE

DISCHARGE SIDE IS HIGH PRESSURE HOT GAS
LIQUID SIDE IS HIGH PRESSURE LIQUID
SUCTION SIDE IS LOW PRESSURE COOL GAS.
RV = REVERSING VALVE IS NOT ENERGIZED
CAP = CAPILLARY TUBE (METERING DEVICE)
TXV = THERMOSTATIC EXPANSION VALVE (METERING DEVICE)
CHK VLV = CHECK VALVE

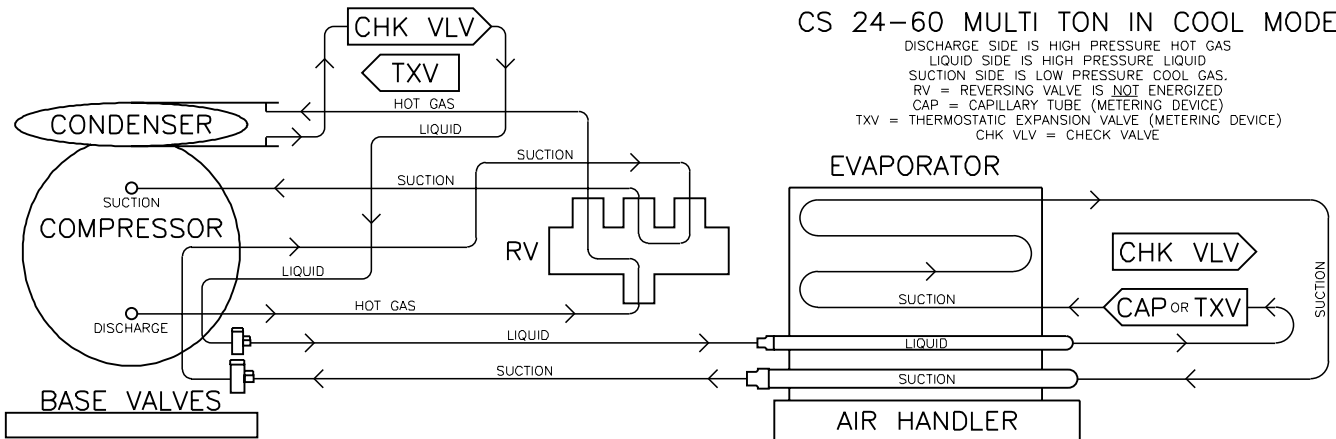

CS 24-60 MULTI TON IN HEAT MODE

DISCHARGE SIDE IS HIGH PRESSURE HOT GAS
LIQUID SIDE IS HIGH PRESSURE LIQUID
SUCTION SIDE IS LOW PRESSURE COOL GAS.
RV = REVERSING VALVE IS ENERGIZED IN HEAT
CAP = CAPILLARY TUBE (METERING DEVICE)
TXV = THERMOSTATIC EXPANSION VALVE (METERING DEVICE)
CHK VLV = CHECK VALVE

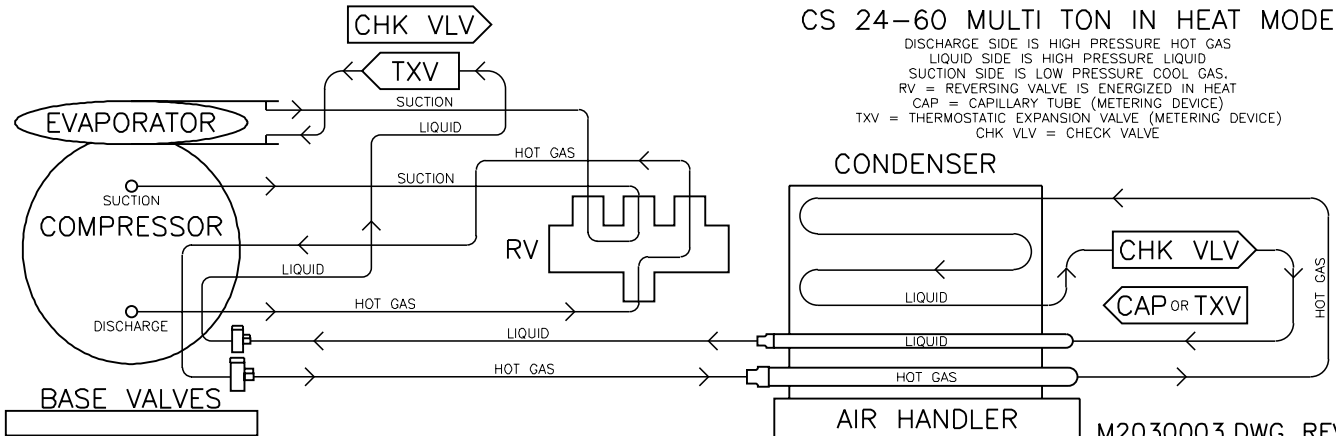

M2030003.DWG REV:B

refrigerant travels along the liquid line to the TXV on the condensing unit where it is metered into the condenser coil, which is now acting as an evaporator. Heat is absorbed from the water by the refrigerant as it passes through the coil. The vapor returns to the compressor via the reversing valve.

SUPPLY & RETURN AIR GRILLES

Install the supply air grille as high as possible in a location that will provide uniform air distribution throughout the cabin, grille louvers should be directed upward. The return air grille should be installed as low and close to the a/c unit as possible to insure direct uninterrupted airflow to the evaporator. The return air grille should have a minimum four inches (4") of clearance in front of it, free from any furniture or other obstructions. In no instance should a supply air discharge be directed towards a return air grille, as this will cause the system to short cycle. Allow for adequate clearance behind the supply air grille(s) for the transition box and ducting connection. The following table shows minimum grille sizes. See the MAINTENANCE section of this manual for return air filter cleaning instructions.

DUCTING

Good airflow is critical for the performance of the entire system. It is highly dependent on the quality of the ducting installation. The ducting should be run as straight, smooth and taut as possible minimizing the number of 90 degree bends (two tight 90 degree bends can reduce airflow by 25%). The following table shows minimum duct diameters and their corresponding supply and return air grille minimum areas in square inches. If a transition box is used, the total area of supply air ducts going out of the box should equal the area of the supply duct feeding the box. To calculate the square inch area of a round duct, multiply the radius (which is half of the diameter) by itself (r^2) and multiply that number by 3.1416 (π).

MODEL	E4FD/Z	E6FD/Z	E9FD/Z	E12FD/Z	E16FD/Z	E24FD/Z
DUCT DIAMETER	5" dia	5"dia	5"dia	6" dia	7"dia	8"dia
DUCT AREA	19.6 sq in	19.6 sq in	19.6 sq/in	28.3 sq in	38.5 sq in	50.3 sq in
Return Air GRILLE	88 sq in	88 sq in	98 sq in	140 sq in	168 sq in	280 sq in
Supply Air GRILLE	40 sq in	40 sq in	50 sq in	70 sq in	84 sq in	140 sq in

The following is a summary of proper ducting connections:

1. Pull back the fiberglass insulation exposing the inner mylar duct hose.
2. Slide the mylar duct hose around the mount ring until it bottoms out.
3. Screw 3 or 4 stainless steel sheet metal screws through the duct hose into the transition ring.
Make sure to catch the wire in the duct hose with the heads of the screws. Do not use band clamps, as the hose will slide off.
4. Wrap duct tape around the ducting and ring joint to prevent any air leaks.
5. Pull the insulation back up over the mylar to the ring and tape the joint.
6. Remove excess ducting and use the same connection method at the s/a grille.

All ducting should:

- Be appropriately sized for each application.
- Run as smoothly and taut as possible.
- Have as few bends or loops as possible.
- Be securely fastened to prevent sagging during boat operation.
- Have all excess ducting lengths trimmed off.
- Not be flattened or kinked.
- Insulated when located in high heat load areas (hull side, mechanical compartments, etc.).
- Be properly protected against potential damage when routed through open areas.

SEAWATER PUMP AND PLUMBING

Several guidelines should be followed during the installation of the seawater system. Since the circulation pump is centrifugal and not self-priming, it must be mounted so that it is always at least one foot below the water line regardless of which tack the vessel is on. Pump may be mounted horizontally or vertically, however the discharge must always be above the inlet. Pump head should be rotated toward the direction of water flow. **Install the seawater speed scoop intake as far below the water line and as close to the keel as possible in any application, but especially on a sailboat, to keep the intake in the water when the boat heels over so that air does not get into the system.** The speed scoop intake must face forward and not be shared with any other pump. A seawater strainer is mandatory between the shut off valve (seacock) and the pump to protect the pump from any foreign matter. **Failure to install a seawater strainer will void the pump warranty.** The seawater system should be installed with an upward incline from the speed scoop & seacock, through the strainer, to the inlet of the pump and then up to the inlet of the a/c unit's condenser coil. The discharge from the a/c unit should then run to the seawater outlet thru-hull fitting which should be located where it can be visually checked for water flow and as close as practicable to the waterline to reduce noise. All hose connections shall be secured by means of double/reversed stainless steel hose clamps. Use teflon tape on all threaded connections.

The following is a summary of the seawater system installation:

1. Install the speed scoop thru-hull inlet as close to the keel and as far below the water line as possible, facing forward. Bed the scoop with a marine sealant designed for underwater use.
2. Install a bronze, full flow seacock on the speed scoop thru-hull inlet.
3. Install a seawater strainer below the level of the pump with access to filter.
4. Mount the pump above the strainer and at least one foot below the waterline.
5. Connect the seacock and strainer with an uphill run of 5/8" reinforced marine grade hose.
6. Connect the discharge from the pump uphill to the bottom inlet of the a/c unit's condenser coil with 5/8" hose. Connect the discharge from the condenser coil to the overboard discharge thru-hull fitting with 5/8" hose.
7. Avoid loops, high spots or the use of 90° elbows with seawater hose (each 90° elbow is equivalent to 2.5' of hose and a 90° elbow on the pump outlet is equivalent to 20' of hose).
8. Double clamp all hose connections with stainless steel clamps, reversing the clamps.
9. Use teflon tape on all threaded connections.
10. **Connect all metallic parts in contact with seawater to the vessel's bonding system including the speed scoop inlet, strainer, pump and the air conditioner. Failure to do so will void warranty.**

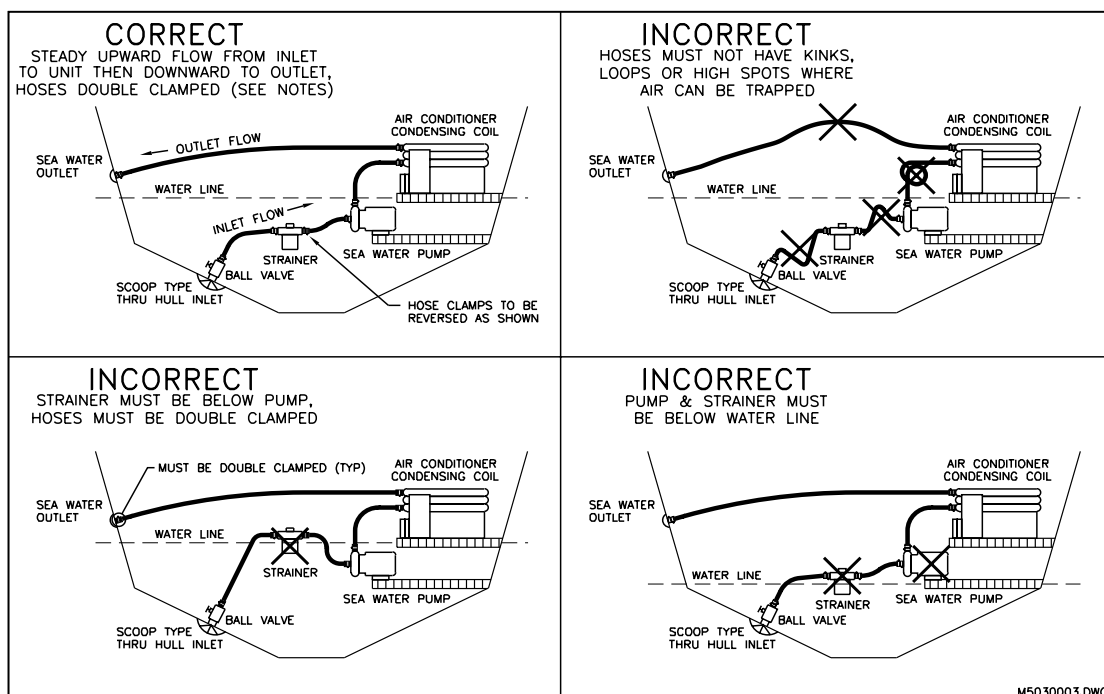

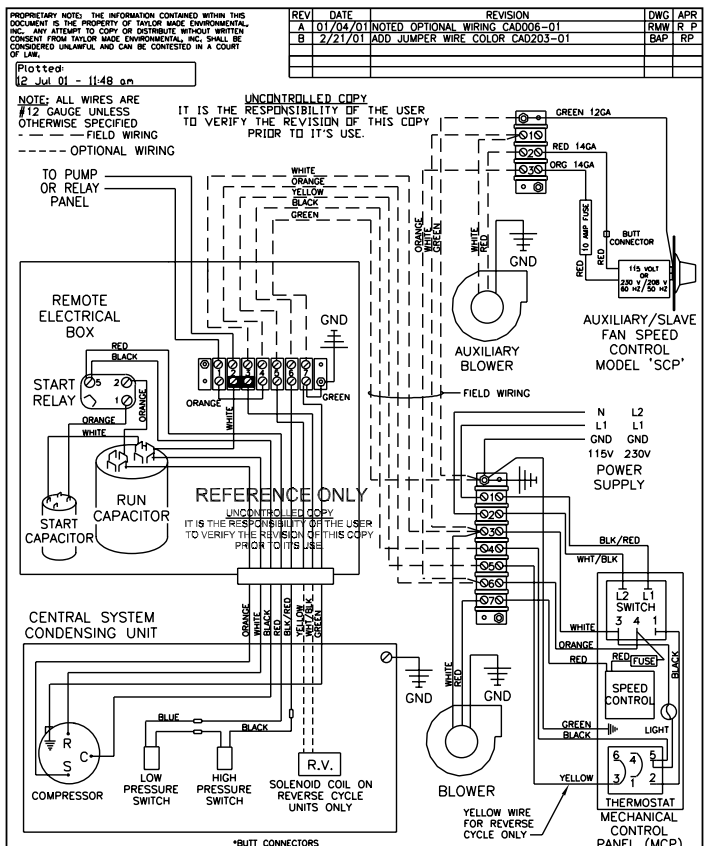

DATE: 12/07/00	WIRING DIAGRAM	
PART NUMBER: 334908	CSM6-48K(-Z/C/CZ)	
SCALE: N.T.S.	CENTRAL SYSTEM with MCP	
DESIGN BY: APPROVED BY: RMW R P	115-230VAC/50-60HZ/1Ø	
	M2010064B	

PROPRIETARY NOTE: THE INFORMATION CONTAINED WITHIN THIS DOCUMENT IS THE PROPERTY OF TAYLOR MADE ENVIRONMENTAL, INC. ANY ATTEMPT TO COPY OR DISTRIBUTE WITHOUT WRITTEN CONSENT FROM TAYLOR MADE ENVIRONMENTAL, INC. SHALL BE CONSIDERED UNLAWFUL AND CAN BE CONTESTED IN A COURT OF LAW.

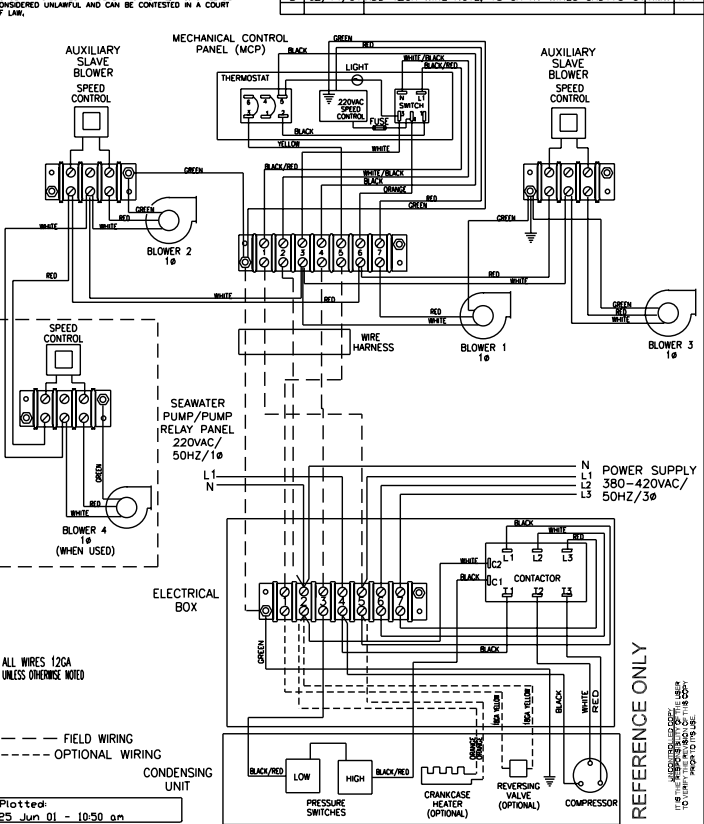

DATE: 12/15/00	WIRING DIAGRAM	
PART NUMBER: 334907	CSM24-60K-3 PHASE	
SCALE: N.T.S.	MULTI TON with MCP & SCP	
DESIGN BY: APPROVED BY: RMW R P	380-420VAC/50HZ/3Ø	
	M2010063	

PROPRIETARY NOTE: THE INFORMATION CONTAINED WITHIN THIS DOCUMENT IS THE PROPERTY OF TAYLOR MADE ENVIRONMENTAL, INC. ANY ATTEMPT TO COPY OR DISTRIBUTE WITHOUT WRITTEN CONSENT FROM TAYLOR MADE ENVIRONMENTAL, INC. SHALL BE CONSIDERED UNLAWFUL AND CAN BE CONTESTED IN A COURT OF LAW.

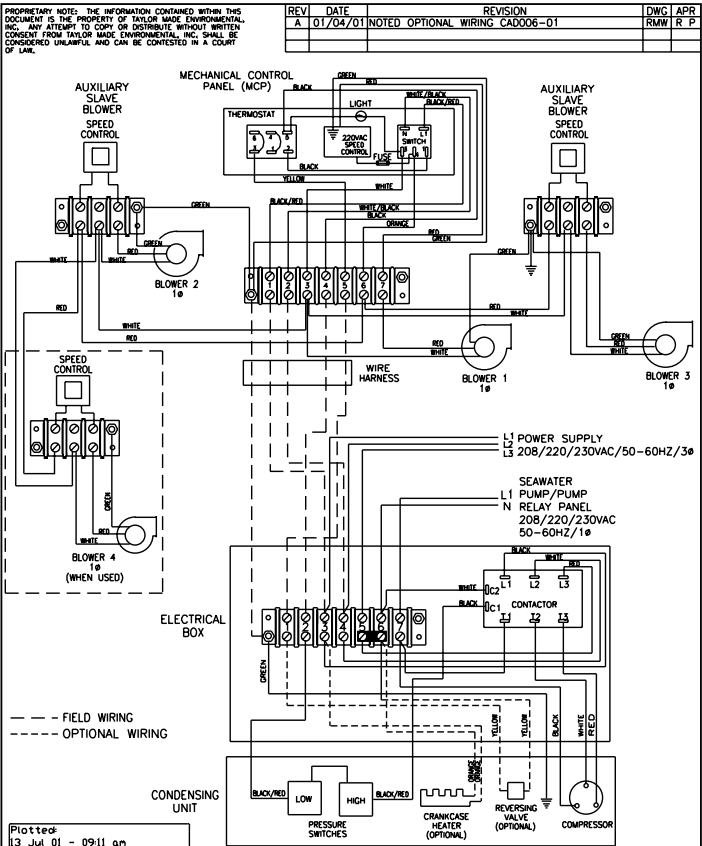

DATE: 12/08/00	WIRING DIAGRAM	
PART NUMBER: 334905	CSM24-60K-3 PHASE	
SCALE: N.T.S.	MULTI TON with MCP & SCP	
DESIGN BY: APPROVED BY: RMW R P	208/220/230VAC/50-60HZ/3Ø	
	M2010061	

PROPRIETARY NOTE: THE INFORMATION CONTAINED WITHIN THIS DOCUMENT IS THE PROPERTY OF TAYLOR MADE ENVIRONMENTAL, INC. ANY ATTEMPT TO COPY OR DISTRIBUTE WITHOUT WRITTEN CONSENT FROM TAYLOR MADE ENVIRONMENTAL, INC. SHALL BE CONSIDERED UNLAWFUL AND CAN BE CONTESTED IN A COURT OF LAW.

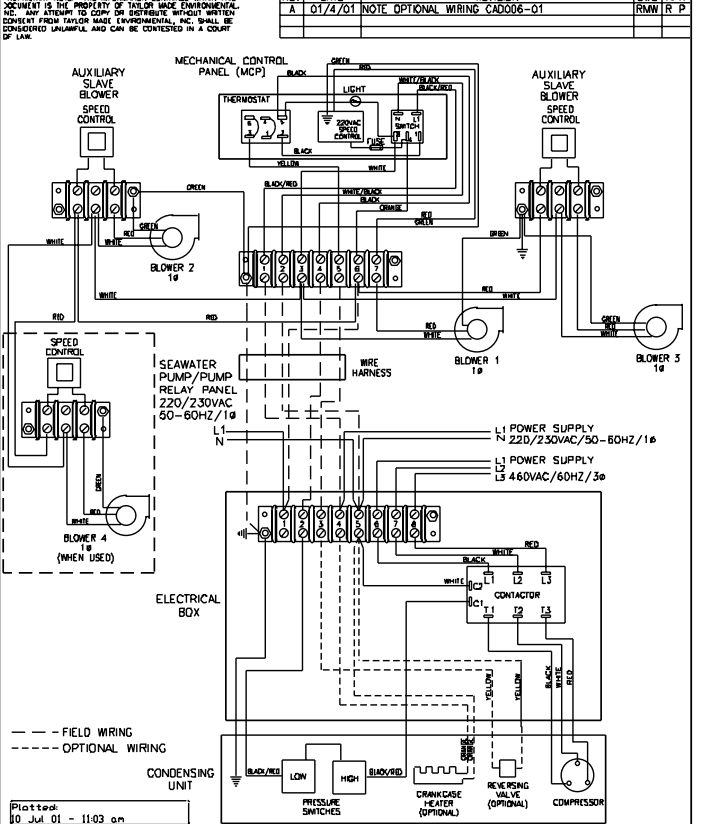

DATE: 12/06/00	WIRING DIAGRAM	
PART NUMBER: 334906	CSM24-60K-3 PHASE	
SCALE: N.T.S.	MULTI TON with MCP & SCP	
DESIGN BY: APPROVED BY: RMW R P	460VAC/60HZ/3Ø	
	M2010062	

PROPRIETARY NOTE: THE INFORMATION CONTAINED WITHIN THIS DOCUMENT IS THE PROPERTY OF TAYLOR MADE ENVIRONMENTAL, INC. ANY ATTEMPT TO COPY OR DISTRIBUTE WITHOUT WRITTEN CONSENT FROM TAYLOR MADE ENVIRONMENTAL, INC. SHALL BE CONSIDERED UNLAWFUL AND CAN BE CONTESTED IN A COURT OF LAW.

Central Systems Wiring Diagrams Passport®II Control

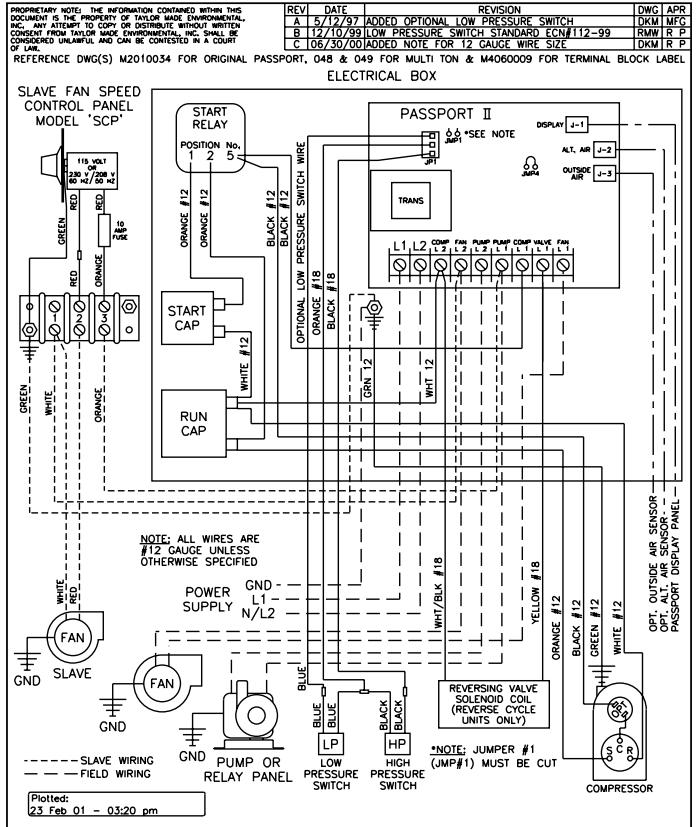

DATE: 9-12-96	WIRING DIAGRAM	CSP6-16K(-Z/C/CZ) CENTRAL SYSTEM with PASSPORT II 115-230VAC/50-60HZ/1ø	
PART NUMBER: 332756	SCALE: N.T.S.		
DESIGN BY: DKM	APPROVED BY: DKM	DRAWING NO: M2010047C	

REV	DATE	REVISION	DWG	APR

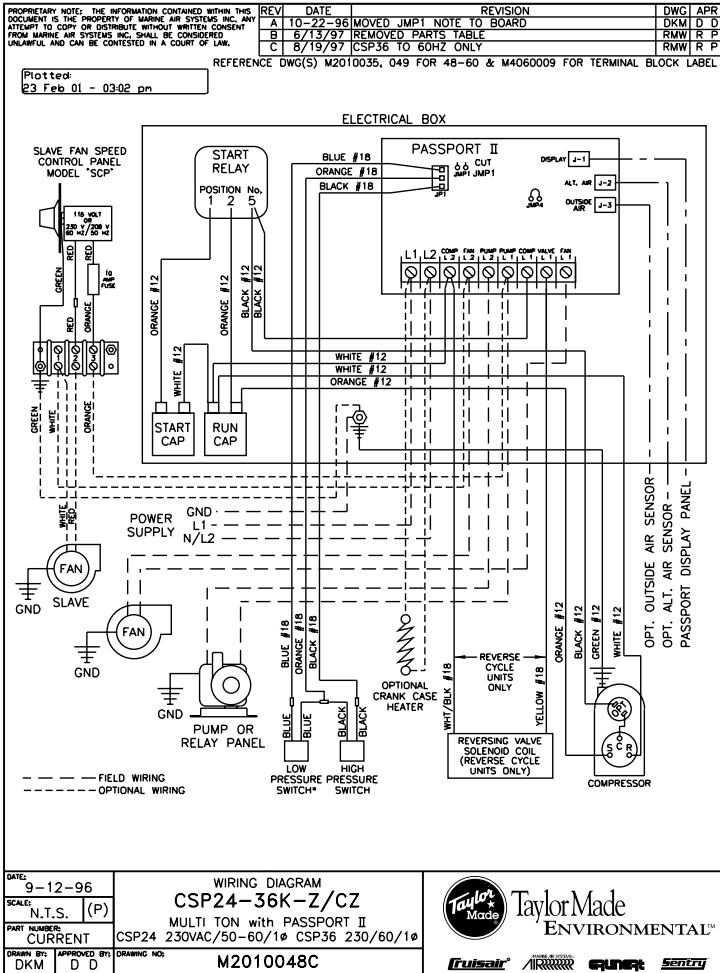

DATE: 9-12-96	WIRING DIAGRAM	CSP24-36K(-Z/CZ) MULTI TON with PASSPORT II 230VAC/50-60/1ø CSP36 230/60/1ø	
SCALE: N.T.S. (P)	SCALE: N.T.S. (P)		
PART NUMBER: CURRENT	DESIGN BY: DKM	APPROVED BY: DKM	DRAWING NO: M2010048C

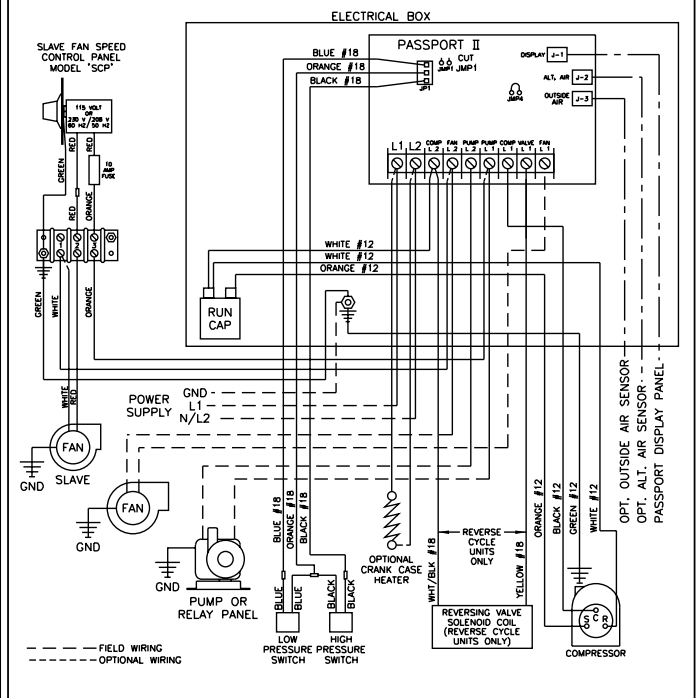

DATE: 4/21/98	WIRING DIAGRAM	CSP24-36K (-Z/CZ) MULTITON w/SCROLL COMP. & PASSPORT II 230VAC/50-60/1ø	
SCALE: N.T.S. (P)	SCALE: N.T.S. (P)		
PART NUMBER: CURRENT	DESIGN BY: RWM	APPROVED BY: R P	DRAWING NO: M2010057

Central Systems Wiring Diagrams Passport®II Control

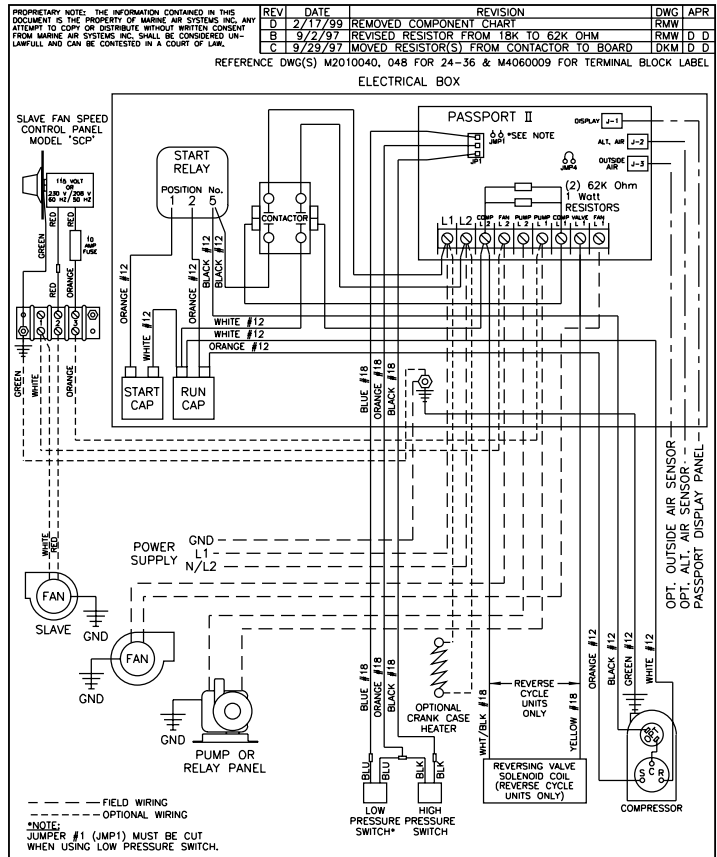

DATE: 10-16-96	WIRING DIAGRAM	CSP36-60K-Z/CZ	
SCALE: N.T.S. (P)	MULTI TON with PASSPORT II		
SHEETS: CURRENT	CSP36 230/50/1Ø CSP48-60 230/50-60/1Ø	M2010049D	
DRAWN BY: DKM	APPROVED BY: D D		

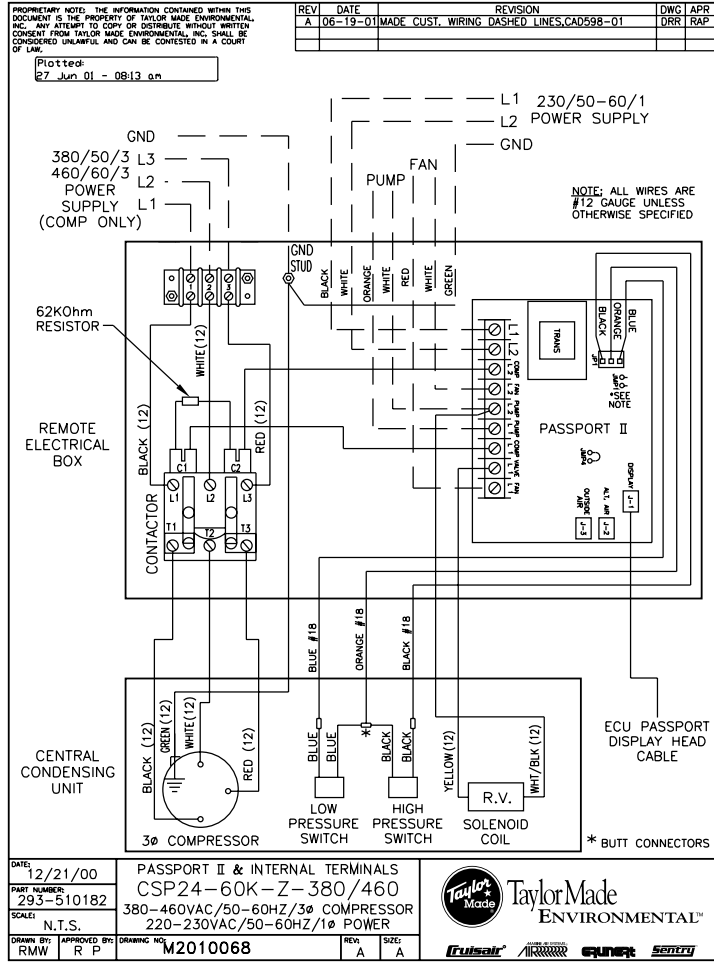
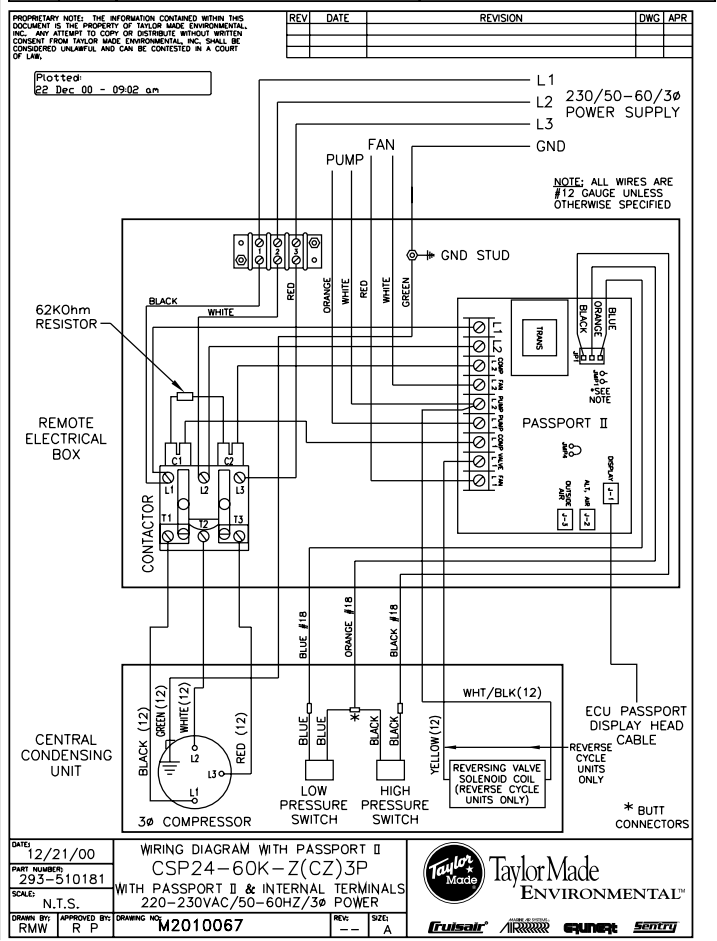

MANUAL CONTROL PANEL (MCP) INSTALLATION

The MCP should be located within cap tube length of the a/c unit. The 3 knob MCP is configured either vertically (shown) or horizontally. The cut out size is 2.5" by 7.0", see MCP for orientation. Once the cut out is made, carefully uncoil the copper cap tube with return air sensor (copper bulb) and route the control wires and cap tube through the hole and back to the a/c unit **using caution not to kink the cap tube**. Mount the return air sensor into the clips provided on the evaporator coil. If the return air sensor cannot be mounted on the evaporator coil, mount it behind the return air grille. The sensor must be mounted in the return air stream. Make electrical connections according to the wiring diagram found in the electric box and/or in the operations manual.

MCP OPERATION

- 1) Ensure seawater intake ball valve (sea cock) is open.
- 2) Turn SYSTEM SWITCH control knob to OFF.
- 3) Turn on AC circuit breaker. If the seawater pump has its own circuit breaker, turn that on too.
- 4) Turn the SYSTEM SWITCH control knob to START; this energizes the fan and seawater pump. Turn THERMOSTAT control knob to the coolest position by rotating fully clockwise. If system has reverse cycle, turn knob counter-clockwise for heat.
- 5) Check for a steady solid stream of seawater from the overboard discharge.
- 6) Turn FAN SPEED control knob clockwise to highest setting.
- 7) Verify that the fan is running and that there is steady airflow out of the supply air grille.
- 8) Turn the SYSTEM SWITCH to RUN; this will start the compressor. The indicator light on the control will illuminate.
- 9) To set the thermostat, allow sufficient time for the unit to cool/heat the area to the desired temperature. When the area is sufficiently cooled/heated, turn the thermostat knob slowly toward the center position until it clicks once (the indicator light will turn off). The thermostat is now set to maintain a constant temperature. While heating (if reverse cycle only), if the ambient temperature is less than 50°F, set the FAN SPEED control knob to low for five to ten minutes until the unit begins to heat well, then increase the fan speed for more heat output.

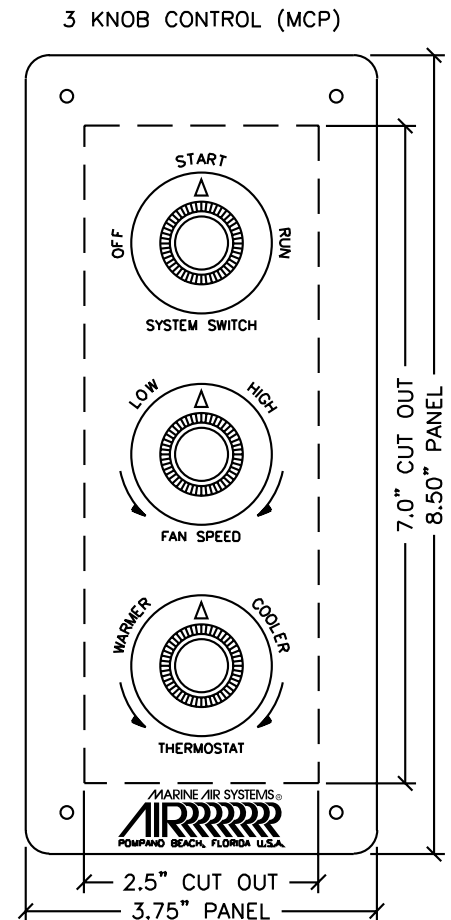

The thermostat on the MCP control panel serves to cycle the compressor on and off and provide an automatic changeover from cooling to heating (reverse cycle only) with a 3.5° differential. Rotating the thermostat to the left after it has been set for cooling will cause the unit to heat. If you rotate the thermostat to the right, the unit will cool. If the thermostat is left stationary after being set, the unit will cycle from cooling to neutral, or heating to neutral depending on the requirement.

Reverse cycle units have a reversing valve that must be energized periodically to keep the internal parts moving freely. To accomplish this, switch the a/c into HEAT for a few seconds once a month.

Note: Do not turn the unit off and immediately turn it back on. Wait at least 30 seconds.

SLAVE FAN SPEED CONTROL

On multiple evaporator systems only one air handler is dedicated as the master control and the others are slaved from that circuit. Usually the largest capacity air handler or the one dedicated to the most frequently occupied space is chosen as the main control unit. When the master control unit energizes, all of the slave controls turn on. The only function of the slave speed control (model SCP) is controlling the speed of the fan on that air handler. Any air handler's fan speed is controlled by a triac, whether it is controlled from the Passport®II circuit board, mechanical 3-knob control (MCP) or slave fan speed control panel (SCP). Connecting triacs in series would negatively affect the performance of the fans; therefore auxiliary/slave fans should be wired to the master unit's pump control output - see the wiring diagrams included in this manual and in the condensing units' electrical box.

PASSPORT II DISPLAY PANEL INSTALLATION

Before mounting the Passport II digital display panel touch pad, consider the location. The air sensor built into the display panel will provide excellent room air temperature sensing given a proper installation. The display panel should be mounted on an inside wall, slightly higher than mid-height of the cabin, in a location with freely circulating air where it can best sense average temperature. The cut out size for the display panel is 33/8" wide by 23/4" high. Do not mount the display in direct sunlight, near any heat producing appliances or in a bulkhead where temperatures radiating from behind the panel may effect performance.

Do not mount the display in the supply air stream. Do not mount the display above or below a supply or return air grille. Do not mount the display behind a door, in a corner, under a stairwell or any place where there is no freely circulating air. Mount the display within display cable length (custom lengths available) of the air conditioner. Plug the display cable (15'4.6m standard length with 8-pin connector) into the circuit board in the electric box and into the back of the display panel. Secure the display panel to a bulkhead with the adhesive strips provided. Clean the mounting surface with *isopropyl alcohol only* prior to placement (test alcohol on hidden portion of surface first). If the adhesive strips cannot be used directly on the bulkhead then use the plastic bulkhead adapter. The bulkhead adapter (sold separately) is mounted to the bulkhead with screws and the display panel is secured to the adapter with adhesive strips. **Do not use a screw gun and do not over-tighten screws when mounting adapter.**

If a proper location for room temperature sensing cannot be found for the display, an optional remote air sensor may be used. Mount the remote air sensor in the return air stream behind the return air grille/opening and plug its cable (7'2.1m standard length with 6-pin connector) into socket #J2 on the circuit board (socket nearest the corner of the board). Installing the remote air sensor will override the face plate sensor. An optional outside air temperature (O.A.T.) sensor and cable may also be used. Plug the O.A.T. cable into the 6-pin socket #J3. Mount the sensor outside in a protected location and not in direct sunlight. Air sensor cables are available in various lengths. Secure all cables but do not staple when mounting.

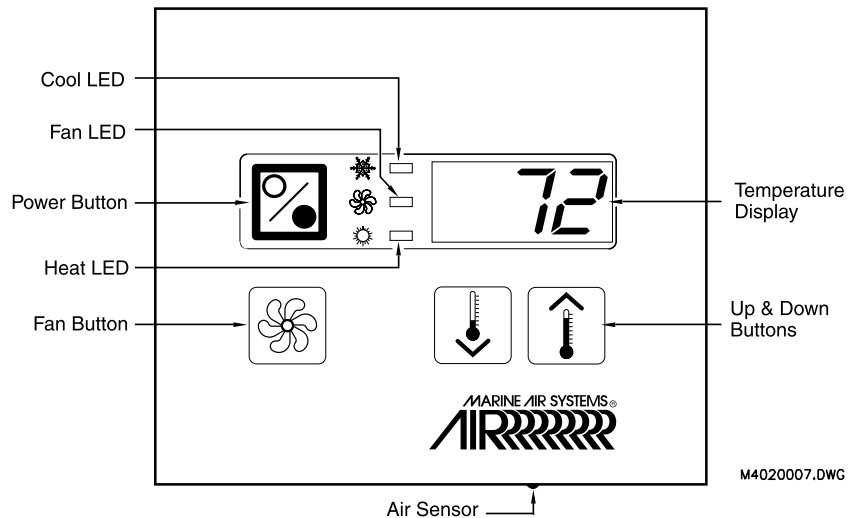

INSTALLATION CHECKLIST (review prior to installation)

Seawater cooling system:

- Speed scoop located as far below the water line and as close to the keel as possible
- Shut off valve and speed scoop properly sealed and tight
- Seawater pump is at least one foot below water line and securely mounted
- Strainer mounted below pump with access to filter
- Double/reversed stainless steel hose clamps on all hose connections
- Teflon tape on all threaded connections
- Hose runs uphill from speed scoop and sea cock to strainer, pump and a/c unit, then downhill (if possible) from a/c unit to overboard discharge
- Water flowing freely from overboard discharge while pump is running
- Pump relay panel, if used, must have its own circuit breaker sized for the pump (20 amp max)
- All metal fittings should be bonded

Mounting

- Air handler not in engine room or bilge areas, must be sealed away from exhaust or fumes
- Proper spacing allowed around unit
- Attached to solid level platform with hold down clips provided
- Condensate drain routed aft and down hill to a sealed sump (not bilge)
- Blower rotated toward supply air grille

Electrical

- All butt connections on pump wire tightly crimped and heat shrunk
- AC power source installed and grounded/bonded in accordance with ABYC standards
- Control wires connected to terminal strip with fork or ring terminals
- Circuit breakers sized according to specifications on the data plate label
- Remote electrical box mounted with position sensitive relay taken into consideration
- Passport II display cable is connected at both ends
- Pump Relay Panel (if used) has a dedicated circuit breaker sized for the pump but not to exceed 20 amps maximum.

Grilles and Ducting

- Supply air grille mounted as high as possible
- Return air grille mounted as low and as close to the a/c unit as possible
- Return air grille mounted away from bilge vapors or exhaust fumes
- Ducting is pulled taut, straight, smooth and properly connected with no excess

Line Sets

- Pressure tested
- Evacuated
- No kinks or crushed piping and no vertical loops
- Correct insulation thickness and properly sealed
- Piping supported

QUICK START OPERATIONS CHECKLIST

- Ensure seawater intake ball valve (sea cock) is open.
- Turn on the A/C circuit breaker. If the seawater pump has its own circuit breaker, turn that on.
- Turn the system on.
- Set the desired cabin temperature (set point).
- Check for a steady solid stream of water from the overboard discharge.
- Verify that there is steady airflow out of the supply air grille.
- If the unit does not appear to be operating properly, refer to troubleshooting guidelines.

Note: Do not turn the unit off and immediately turn it back on. Allow at least 30 seconds for refrigerant pressure equalization.

PASSPORT® II CONTROL



POWER BUTTON: Press and release to turn unit on and off.

NOTE: To “press and release” a button, press and hold for one second and then release.



FAN BUTTON: Press and hold until the letter “A” appears for automatic fan speed or the numbers “1” (slow) through “6” (fast) appear for manual fan speed. Fan may be used while a/c is off.



UP & DOWN BUTTONS: Press and hold either button until desired temperature (set point) is displayed. Press either button momentarily to show current set point. Range = 60°-85°F.

COOL LED: Lights when the compressor is running in cool mode or in automatic mode while cooling.

FAN LED: Lights when fan is on in manual mode.

HEAT LED: Lights when the compressor is running in heat mode, or automatic mode while heating.

DISPLAY WINDOW: Shows current cabin temperature. It can also show outside air temperature if the optional O.A.T. sensor is installed. Also used in viewing and setting program parameters.

AIR SENSOR: Cabin temperature is detected by the face plate air sensor, located in the bottom edge of the display. A remote air sensor can be installed if needed. Installing the remote air sensor will override the face plate sensor.

BLANK DISPLAY FOR NIGHTTIME OPERATION: Press the FAN and DOWN buttons simultaneously to blank the display for nighttime operation. The appropriate LEDs will remain lit during cooling and heating. When the desired temperature has been achieved, the middle segment of the display window will remain lit to indicate that the system is on. Press any button to return to normal display mode.

OUTSIDE AIR TEMPERATURE: When the optional outside air sensor is installed, press the UP and DOWN buttons simultaneously to display the outside air temperature. The outside air sensor should not be mounted in direct sunlight.

MODES OF OPERATION

COOL ONLY MODE: When the Passport II is configured for cool only mode, only cooling systems will be operated as required. When the temperature drops below the set point the system will not automatically switch into the heating mode.

HEAT ONLY MODE: When the controller is programmed for heating mode, only the heating system will be selected for operation as required. Should the temperature rise above the set point the system will not switch to the cooling mode automatically.

AUTOMATIC MODE: When the controller is configured for the automatic mode, both heating and cooling will be supplied as required. The heat and cool LED indicators will light according to which mode is operating. Temperature differential in a given mode will be maintained at 2°F, however, a 4°F difference is required to allow the control to change modes.

HUMIDITY MODE: While the system is on, press the POWER and the DOWN buttons simultaneously to enter the humidity or moisture control mode. The characters “HU-1” will appear in the temperature display. Every four hours, the fan is started and air is circulated for thirty minutes. During this time the air temperature is sampled and entered into memory. The cooling cycle is then started and continues until the temperature is lowered 2°F. The compressor is allowed a maximum of one hour running time to reach the desired temperature. Four hours after the temperature is satisfied or the compressor times out, the cycle is repeated. During the cycle, the cool LED will be lit when the compressor is running. Humidity mode is provided to maintain a specific temperature and humidity range when the vessel is unoccupied for extended periods of time.

AUTOMATIC FAN MODE: Press and hold the FAN button until the letter “A” appears in the display window. Automatic fan mode allows the control to determine fan speeds based on the room temperature. The closer the room temperature gets to the set point, the slower the fan will run while in cool mode. This permits a balance between the most efficient temperature control and the slowest fan speed. See programmable parameter “U 9” to reverse the fan speeds while in heat mode. The fan LED will not be lit during automatic fan mode.

MANUAL FAN MODE: Press and hold the FAN button during normal operation to select one of the six manual fan speeds available. Six (6) is the highest and one (1) represents the lowest speed available. When a manual fan speed has been selected the fan LED will be lit.

NOTE: High and low fan speeds can be further tailored to suit the user by adjusting the fan limits. See programming modes “U 2” and “U 3”.

CIRCULATION MODE (FAN ONLY): With the system off, press and hold the FAN button until the desired fan speed is indicated by the numbers “1” (slow) through “6” (fast). To turn the fan off press and hold the FAN button until the number “0” appears in the display window.

PROGRAMMING THE PASSPORT II

The program mode is used to adjust operating parameters to tailor the system for efficient operation and to allow for user flexibility. Installation variables such as ducting, sensor location and system layout effect the operation of the overall system. Custom programming allows the system to operate as efficiently as possible in any given installation.

TO ENTER PROGRAM MODE: With the system off, press and hold the POWER button for five seconds until the letter “U” appears in the display window. Release the button and the first parameter setting appears followed by “U 1”.

TO UNLOCK PROGRAM MODE: After entering the program mode, simultaneously press and release the POWER and DOWN buttons.

TO SELECT PROGRAM PARAMETER: Press and hold the FAN button to scroll through the parameters indicated by the program number. Programs are described in the following table.

TO CHANGE THE PROGRAM PARAMETER: Use the UP and DOWN buttons to select data or set the desired limits. The range of parameter settings is listed in the following table.

TO RESET DEFAULT SETTINGS: With the system off, press and hold the POWER button for ten seconds until the software version number (A##) appears in the display window.

TO LOCK NEW DEFAULT SETTINGS: Once the desired program changes have been made and before exiting the program mode, simultaneously press and release the UP and DOWN buttons. Locking new defaults will render the factory defaults obsolete. Make note of the new defaults in the following table for future reference.

TO EXIT PROGRAM MODE: Press the POWER button or press no button for sixty seconds. The software version number is displayed for one second prior to exiting the program mode.

PROGRAMMABLE PARAMETERS

Program Number	Description	Default Setting	New** Default	Range
U1	Operating Mode	0 or 1*		0 = Automatic Mode 1 = Cool Only Mode 2 = Heat Only Mode
U2	High Fan Speed Limit	85		56-85
U3	Low Fan Speed Limit	50		30-55
U4	Compressor Staging Time Delay	15 or 135*		5-135 Seconds
U5	Temperature Calibration	0		±10°F
U6	Compressor Fail-Safe Protection HHH=high freon pressure PPP=low freon pressure	3		0=Fail-Safe Protection OFF 1=Continuous Restarts, No Display 2=Continuous Restarts, With Display 3=3 Failures w/Display, Reset Required
U7	Fahrenheit or Celcius Temperature Display	0		0=°F 1=°C
U8	Not Used	-		-
U9	Reversed Fan Speeds During Heating	1		0=Fan speed decreases as set point is approached 1=Reversed Fan Speeds
U10	Continuous Fan Operation or Cycle Fan with Compressor	1		0=Cycle Fan with Compressor 1=Continuous Fan Operation
U11	Reverse Cycle or Electric Heat Option Installed	0		0=Reverse Cycle Heat 1=Electric Heat
U12	Fan Motor	Set at Factory		0=Shaded Pole Fan Motor 1=Split Capacitor Fan Motor
U15	De-Icing Cycle	0		0=Off, 1=One Minute 2=Two Minutes, 3=Three Minutes

* Specific default settings for cool only a/c units (no heat option installed) should not be changed.

** Default parameter settings may be reprogrammed by user, enter new default setting in this column.

U 1 OPERATING MODE: The operating mode is used to select heating, cooling, or automatic modes. Zero (0) selects automatic mode, one (1) selects cooling mode and two (2) selects heating mode. Systems that do not have heating capabilities should be programmed for cooling mode (1). The factory default is zero (0) for automatic mode for reverse cycle units or one (1) for cool only mode for cool only units.

U 2 HIGH FAN SPEED LIMIT: The high fan speed limit can be tailored to suit various motors and operating conditions. The range of values is 56 through 85 in arbitrary units. The factory default is 85.

U 3 LOW FAN SPEED LIMIT: The low fan speed limit determines the lowest output allowed for the low fan speed. The range of values is 30 through 55 in arbitrary units. The factory default is 50.

Both the high and low fan limits may be adjusted as follows: While the system is off, start the fan by pressing and holding the FAN button until the number “1” appears in the display. Enter the program mode while the fan is running and select “U 2” or “U 3”. Raising and lowering the fan limits while the fan is running allows the programmer to experience fan speed changes as they are made. Once the high and low fan speed limits are set, the system will automatically reprogram itself to produce six equally spaced fan speeds between them.

U 4 COMPRESSOR STAGING TIME DELAY: The compressor staging time delay is provided for use where more than one a/c system is being operated from the same power source. Setting the staging delays at different intervals allows for only one compressor to start at a time to lessen the amperage load on the power source. The minimum delay is five (5) seconds and the maximum is one hundred thirty five (135) seconds. The factory default setting is fifteen (15) seconds for reverse cycle units or one hundred thirty five (135) seconds for cool only units.

U 5 TEMPERATURE CALIBRATION: Use this feature to calibrate the air sensor within a range of 10°F. The factory default is 0°F.

U 6 COMPRESSOR FAIL-SAFE PROTECTION: This feature is provided to monitor the refrigerant circuit. When a high head pressure condition occurs the display will flash “HHH”, when the refrigerant system is low on pressure “PPP” will flash only if the optional low pressure switch is installed. This display indicates that the system requires maintenance. See the troubleshooting guidelines in this manual. The factory default is three (3). The four parameter settings are:

Zero (0): Turns off all protection, no action is taken and no message displayed.

One (1): No message displayed with 90 seconds between continuous restarts.

Two (2): Message displayed with 90 seconds between continuous restarts.

Three (3): Message displayed with three 90 second restarts, manual reset is required.

U 7 FAHRENHEIT OR CELSIUS TEMPERATURE DISPLAY: The PASSPORT II can display temperature in either degrees Fahrenheit (°F) or degrees Celsius (°C). Setting to zero (0) displays °F and setting to one (1) displays °C. The factory default is zero (0).

U 8 NOT USED

U 9 REVERSED FAN SPEEDS DURING HEATING: During normal operation in the cooling mode with the fan speed set to “A” (automatic), the fan speed is reduced as the set point temperature is approached. During heating, this is not always the preferred method of operation. When this parameter is set to one (1), the fan speed will increase as the set point is approached during heating. This will reduce head pressure by increasing airflow across the coil as the set point is approached. Setting the parameter to zero (0) will cause the fan speed to decrease as the set point is approached during heating, as it does in the cooling mode. The factory default is one (1).

U10 CONTINUOUS FAN OPERATION OR CYCLE FAN WITH COMPRESSOR: The fan can be programmed to run continuously while the system is on, or can be allowed to cycle with the compressor. When cycled with the compressor, the fan will only operate when cooling or reverse cycle heating is called for. To cycle the fan with the compressor, select zero (0). To operate the fan continuously, select one (1). The factory default is one (1).

U11 REVERSE CYCLE OR ELECTRIC HEAT: Units not equipped with reverse cycle heating, or reverse cycle units operating in seawater temperatures below 40°F, may need to have electric heaters added. **IMPORTANT:** the Passport II circuit board reversing valve output is used to control the optional electric heater. The valve output relay can only carry 6 amps, therefore, a heavy-duty contactor must be installed to carry the electric heater current. Select one (1) for the electric heat option, select zero (0) for reverse cycle heating. The factory default is zero (0).

U12 FAN MOTOR TYPE SELECTION: This feature allows the controller to be programmed for the type of motor on the unit’s fan. Zero (0) selects a shaded pole motor, which is used on most units. Select one (1) for units having “HV” or “EBM” in their model number, these units have a split capacitor motor. The controller has been factory programmed for the appropriate motor type.

GENERAL TROUBLESHOOTING GUIDELINES

Also see specific a/c control troubleshooting section following these general guidelines.

FAULT	POSSIBLE REASON	CORRECTION
Will not start	<p>A/C circuit breaker is off</p> <p>Control is not turned on.</p> <p>Wrong wiring at terminal strip.</p> <p>Push-on butt connectors became disconnected during installation.</p> <p>Input line voltage is insufficient.</p>	<p>Turn circuit breaker on at ship's panel.</p> <p>See control operation section in this manual.</p> <p>Check wiring diagram and correct if necessary.</p> <p>Disconnect power supply and open electric box, check wiring diagram, correct if necessary.</p> <p>Check power source (shore/generator) for proper voltage. Check wiring and terminals for proper sizes and connections.</p>
Fan is not running.	Check your specific control troubleshooting section	
No cooling or heating	<p>Temperature set point is above (in cooling) or below (in heating) ambient temperature.</p> <p>Obstructed seawater flow.</p> <p>Seawater pump maybe air-locked.</p> <p>Loss refrigerant gas.</p> <p>Seawater temperature too high for cooling or too low for heating.</p> <p>Coil is iced (in cooling)</p> <p>Fan is not running.</p> <p>Pressure switch or thermal overload opened.</p>	<p>Lower or raise set point.</p> <p>Clean seawater strainer. Check for obstructions at speed scoop thru-hull inlet. Check for a good steady flow from the overboard discharge.</p> <p>Remove hose from pump discharge to purge air from line.</p> <p>Check a/c unit for refrigerant oil leakage, call service technician.</p> <p>Seawater temperature will directly affect a/c unit's efficiency. This a/c unit can effectively cool your boat in water temperature up to 90°F and heat (if reverse cycle option is installed) in water as low as 40°F.</p> <p>See below</p> <p>See below</p> <p>Check you specific control troubleshooting section.</p>
No heating	Unit is "cool only", or if reverse cycle, reversing valve may be stuck.	Tap reversing valve lightly with rubber mallet while unit is in heat mode. Call for service if that does not correct the problem

GENERAL TROUBLESHOOTING GUIDELINES CONTINUED

FAULT	POSSIBLE REASON	CORRECTION
Low air flow	<p>Air flow is blocked</p> <p>Coil is iced</p>	<p>Remove any obstructions in return air stream. Clean return air filter and grille. Check for crushed or restricted ducting, ducting must be as straight, smooth and taut as possible.</p> <p>See below.</p>
Coil is iced	<p>Thermostat set point is too low</p> <p>Improper air flow.</p> <p>Supply air is short-cycling.</p> <p>Seawater temperature is below 40°F.</p> <p>Humidity level too high.</p> <p>When all else fails.</p> <p>Check your specific control troubleshooting section.</p>	<p>Raise set point.</p> <p>Remove any obstructions in return air stream. Clean return air filter and grille. Check for crushed or restricted ducting, ducting must be as straight, smooth and taut as possible.</p> <p>Redirect supply air so that is not blowing into the return air stream. Seal any air leaks on duct.</p> <p>Shut down system to prevent damage to condenser. Allow coil to defrost (see below).</p> <p>Close hatches and doors.</p> <p>Switch a/c to heat until ice melts or use hair dryer to melt.</p>
System runs continuously.	<p>Set point temperature is improperly set: too low for cooling or too high for heating.</p> <p>Porthole or hatches open.</p> <p>Seawater temperature too high for cooling or too low for heating.</p> <p>Improper air sensor location.</p>	<p>Raise or lower set point.</p> <p>Close all port holes and hatches.</p> <p>Seawater temperature will directly affect the a/c unit's efficiency. This a/c unit can effectively cool your boat in water temperatures up to 90°F and heat (if reverse cycle option is installed) in water as low as 40°F.</p> <p>Check your specific control troubleshooting section.</p>

PASSPORT®II DIGITAL CONTROL TROUBLESHOOTING GUIDELINES

FAULT	POSSIBLE REASON	CORRECTION
Passport II display panel is not lit.	8-pin display cable plugs are not making contact (unplugged, dirty, bent, or broken pins).	With POWER OFF at the circuit breaker, remove connector and inspect . If damaged, replace connector or entire display cable.
Fan is not running.	Passport II is programmed for fan cycling with compressor.	Reprogram parameter U10.
Fan runs continuously.	Passport II is programmed for continuous fan operation.	Reprogram parameter U10.
Fan is not running but the compressor is.	Failed triac on Passport II circuit board.	Send for repair or call local service technician (see back of book for a listing).
Fan runs continuously although it is set to cycle with compressor.	Failed triac on Passport II circuit board.	Send for repair or call local service technician (see back of book for a listing).
No cooling or heating.	Passport II programmed for heat or cool only. "HHH" or "PPP" is displayed on PassportII panel.	Reprogram parameter U1 for appropriate mode cooling, heating auto. See below.
No heat.	Parameter U11 may be set to 1.	Programmable parameter U11 must be set to 0.
Unit switches to heat while in cool mode.	Passport II de-icing feature enabled due to coil icing up.	Reprogram parameter U15. If coil is iced, see below.
Coil is iced.	Improper air flow.	Remove obstructions in reterun air stream. Clean air filter and grille. Check for crushed or restricted ducting, ducting must be as straight, smooth and taut as possible. Read Passport II programmable parameter U15 and reset. If de-icing cycle does not melt ice, switch a/c to heat until ice melts or use hair dryer to melt ice. If problem persists program low fan speed parameter (U3) for maximum value (55).
"HHH" is displayed on Passport II.	High-pressure switch is open (in cooling) due to improper seawater flow. High-pressure switch open (in heating) due to improper airflow.	Strainer or intake may be plugged, seacock may be closed, check seawater hose for kinks or collapses. Verify pump operation; check pump circuit breaker if applicable. Remove obstructions in reterun air stream. Clean air filter and grille. Check for crushed or restricted ducting, ducting must be as straight, smooth and taut as possible. If problem persists program low fan speed parameters U3 for maximum value (55). Reprogram parameter U9 for "1" to reverse fan speeds.

PASSPORT®II DIGITAL CONTROL TROUBLESHOOTING GUIDELINES

FAULT	POSSIBLE REASON	CORRECTION
"PPP" is displayed on Passport II.	Low-pressure switch is open due to low seawater and/or low return air temperatures. Low pressure switch is open due to loss of refrigerant.	Try restarting the a/c unit, the optional low pressure switch has a ten minute time delay that may be in affect. Check a/c unit for refrigerant oil leakage, call service technician.
System runs continuously.	Improper Passport II air sensor location.	Verify display head location with criteria found in this manual. Install alternate air sensor if necessary.
"AAA" is displayed	Indicates failed face plate air sensor, alternate air sensor or display cable.	Unplug alternate air sensor if installed or plug in alternate air sensor if not installed. Try another display cable.

MCP MECHANICAL CONTROL PANEL TROUBLESHOOTING GUIDELINES

FAULT	POSSIBLE REASON	CORRECTION
Fan is not running.	MCP system switch is not set properly. MCP fuse blown.	Set MCP system switch to "START" for fan only or "RUN" for cooling and heating (if reverse cycle). Replace 10 amp fuse behind MCP panel.
No cooling or heating.	High pressure switch open (in cooling) due to improper seawater flow. High pressure switch open (in heating) due to improper air flow. Compressor's thermal overload is open due to either of the above reasons.	Strainer or intake may be plugged, sea cock may be closed, check seawater hose for kinks or collapses. Verify pump operation. Check pump circuit breaker if applicable. Remove any obstructions in return air stream. Clean return air filter and grille. Check for crushed or restricted ducting, ducting must be as straight, smooth and taut as possible. Compressor needs to cool down. Turn system off for a while (it may take up to three hours to reset thermal overload).
System runs continuously.	Improper MCP air sensor location.	Verify return air sensing bulb location with criteria found in this manual.

MAINTENANCE

Reversing Valves

Reverse cycle units have a reversing valve; the valve must be energized periodically to keep the internal parts moving freely. To do this, switch the a/c unit into heat for a few seconds once a month.

Seawater Strainer

Insure that your pump receives adequate seawater flow by regularly cleaning the strainer basket. Periodically check the overboard discharge for a steady stream of water. Check seawater intake speed scoop for obstructions. Make sure hoses are not looped, kinked or crushed.

Reversing Valves

Reverse cycle units have a reversing valve; the valve must be energized periodically to keep the internal parts moving freely. To do this, switch the a/c unit into heat for a few seconds once a month.

Blowers

Oil blowers every six months with SAE20 or equivalent (i.e. fractional H.P. motor oil). This does not apply to high velocity blowers with the motor encased in the blower housing.

Condenser Coil Cleaning

1. With the system turned off at the circuit breaker on the ship s panel, disconnect the inlet and outlet connections of the condenser coil.
2. Use chemical resistant hoses (MAS white PVC 5/8" I.D., etc.) to connect the inlet of the condenser coil to the outlet of a chemical resistant, submersible pump (MAS P-500 pump, etc.) and let the hose connected to the coil outlet flow freely into the container mentioned below.
3. Place a strainer or piece of screen over the inlet of the pump and submerge the pump into a container filled with a 5% solution of muriatic or hydrochloric acid and fresh water or use a premixed over-the-counter solution. Use a large container as possible to hold the solution (5-25 gallons). **CAUTION:** avoid spilling or splashing the solution. Follow all warnings and recommendations given by the manufacturer of any acids or pre-mixed solutions.
4. Power the pump and circulate the solution through the condenser coil for 15-45 minutes depending upon the size of the coils and the extent of the contamination. Visual inspection of the solution in the container should indicate when the contamination removal has stopped.
5. Circulate fresh water through the coil to flush any residual acid from the system.
6. Restart the system and check operational parameters to ensure thorough cleaning has taken place. Additional cleaning may be necessary with extreme contamination.

WARNING: For the purpose of protecting the environment, dispose of any contaminated acid solutions in accordance with federal, state and/or local regulations.

Return Air Filters

Check the return air filter about once a month and clean as necessary. To clean the filter, remove it from the unit, rinse with water, air dry and reinstall.

Winterization

There are several methods of winterization, some of which work better than others. The four various methods employed using a 50/50 non-polluting biodegradable anti-freeze/water solution are:

1. Pumping of anti-freeze solution into the overboard thru-hull fitting, and discharging through the intake thru-hull fitting.
2. Use of the seawater pump to pump anti-freeze solution through the system and discharging through the overboard thru-hull fitting. Close sea cock, remove hose from strainer discharge, raise hose above pump (so pump does not lose its prime) and pour in anti-freeze solution. Pump solution through system. The strainer and hose to sea cock will also need to be drained of water.
3. Use of pressurized air injected at the overboard discharge fitting and the water being discharged through the seawater intake fitting.
4. Use of pressurized air to force water from the intake through the overboard discharge.

Any method that causes the anti-freeze solution to flow downward is the method of choice. By this means, the anti-freeze solution will displace any water trapped and eliminate the possibility of freezing in hidden areas. In addition, since the seawater pump utilizes a magnetically driven impeller, the impeller should be removed from the wet end assembly, wiped with an alcohol solution, and stored in a warm, dry area until commissioning takes place.

Note: Collect all discharged liquids and recycle or dispose of in a proper manner.

MANUFACTURERS LIMITED WARRANTY AGREEMENT

The following warranty is extended to cover marine air conditioners manufactured or supplied by Taylor Made Environmental, Inc. (TME), and is subject to qualifications indicated. TME warrants for the periods set forth below that products manufactured or supplied by it will be free from defects in workmanship and material, provided such products are installed, operated, and maintained in accordance with TME's written instruction.

ALL IMPLIED WARRANTIES INCLUDING MERCHANTABILITY AND FITNESS FOR A PARTICULAR PURPOSE, ARE LIMITED TO THE TERMS AND PERIODS OF WARRANTY SET FORTH BELOW AND, TO THE EXTENT PERMITTED BY LAW, ANY AND ALL IMPLIED WARRANTIES ARE EXCLUDED.

Warranty with the Passport®II digital control (Coverage applies to units manufactured on or after 01/01/98 and applies only to units equipped with Passport®II at the TME factory.): Components comprising of the Passport®II circuit boards, display heads and associated cables are warranted for a period of three (3) years from the date of installation, but not to exceed four (4) years from the date of manufacture at the TME factory. All other components comprising a complete system (excluding pumps and pump relay panels) on a new installation are warranted for a period of two (2) years from the date of installation, but not to exceed three (3) years from the date of manufacture at the TME factory. Pumps and pump relay panels are warranted for a period of one (1) year from the date of installation, but not to exceed two (2) years from the date of purchase. OEM installed equipment warranties begin with the purchase of the vessel, not from the date of installation.

Warranty with MCP (Mechanical Control Panel) control:

Components comprising a complete system on a new installation are warranted for a period of one (1) year from the date of installation, but not to exceed two (2) years from the date of manufacture at the TME factory. OEM installed equipment warranties begin with the purchase of the vessel, not from the date of installation.

In addition, TME will pay labor costs and travel as outlined in its **Schedule of Limited Warranty Allowances** for removal and reinstallation of such components for a period of one (1) year from the date of installation, but not to exceed two (2) years from the date of manufacture at the TME factory. OEM installed equipment warranties begin with the purchase of the vessel, not from the date of installation. Warranty will be paid in accordance with our established schedule of allowances. Compensation for warranty repairs is only made to TME authorized service companies.

TME will repair, or replace at its option, components found to be defective due to faulty materials or workmanship, when such components, examined by an authorized service dealer or a factory service representative, are found to have a defect for which the company is responsible. **Refer to Manufacturer's Limited Warranty Policy** for complete coverage and exclusions. Replacement components are warranted for the duration of the remaining warranty period in effect on the original component. In the event that a unit has to be returned to the factory, it must be properly packaged to prevent shipping damages. If packaging is not available, TME will provide it at no charge. The warranty may be voided on any piece of equipment or component that is damaged due to improper packaging.

This limited warranty is extended in lieu of all other warranties, agreements or obligations, expressed or implied, concerning TME's components. This warranty is extended only to the original purchaser and is not transferable. This warranty shall be governed by the laws of the State of Florida and gives the original first end user definite legal rights.

This warranty does not cover damages incidental and/or consequential to the failure of TME's equipment including but not limited to; normal wear, accident, misuse, abuse, negligence, improper installation, lack of reasonable and necessary maintenance, alteration, civil disturbance or acts of God.

No person or dealer is authorized to extend any other warranties or to assume any other liabilities on TME's behalf, unless made or assumed in writing by an officer of TME.

US DISTRIBUTORS

Alabama
Arkansas
Colorado
Kansas
Louisiana
Mississippi
Missouri
Nevada
New Mexico
Oklahoma
Texas
Utah

AER Marine Supply
2301 Nasa Road One
Seabrook, TX 77586
Contact: Richard S. Miller
Tel: (800) 767-7606
(281) 474-3276
Fax: (281) 474-2714
E-mail: rsmiller@aersupply.com
Website: www.aersupply.com

Delaware
Maryland
Pennsylvania
Virginia

Ocean Options - Mid Atlantic
2830 Solomons Island Road
Edgewater, MD 21037
Contact: Mike Bowden
Tel: (800) 400-8043
(410) 266-8033
Fax: (410) 841-2461
E-mail: Sales@oceanoptions.com
Website: www.oceanoptions.com

Georgia
Northern
Florida
North Carolina
South Carolina
Tennessee

Beard Marine Savannah
3101 River Drive
Savannah, GA 31404
Contact: Lynn Stork
Tel: (800) 286-2674
(912) 356-5222
Fax: (912) 692-1006
E-mail: beardsav@aol.com
Website: www.beardmarine.com

New York
New Jersey

Marine Specialists
2231 5th Avenue, Unit 17
Ronkonkoma, NY 11779
Contact: Mike Budney
Tel: (631) 580-0545
Fax: (631) 580-0551
E-mail: Sales@marinespecialists.com
Website: www.marinespecialists.com

Illinois
Indiana
Iowa
Kentucky
Michigan
Minnesota
Ohio
Wisconsin

Midwest Marine Supply
24300 Jefferson Avenue
St. Clair Shores, MI 48080
Contact: Dan Gruninger
Tel: (810) 778-8950
Fax: (810) 778-6108

Connecticut
Maine
Massachusetts
New Hampshire
Rhode Island
Vermont

Ocean Options
95 Riverside Drive
Tiverton, RI 02878
Contact: Mike Bowden
Tel: (401) 624-7334
Fax: (401) 624-8050
E-mail: Sales@oceanoptions.com
Website: www.oceanoptions.com

Idaho
Montana
Oregon
Washington
Wyoming

American Marine Contractors
8313 46th Place West
Mukilteo, WA 98275
Contact: Gene Lawing
Tel: (206) 660-2240
Fax: (425) 740-0246
E-mail: glawing@earthlink.net

Arizona
California
Mexico

A to Z Marine Services
2330 Shelter Island Drive
Suite 104
San Diego, CA 92106
Contact: David Wicks
Tel: (619) 224-1606
Fax: (619) 226-0496
E-mail: info@atozmarine.net

INTERNATIONAL

Please contact us for international dealers & distributors.



Taylor Made Environmental, Inc.
2000 North Andrews Avenue Ext.
Pompano Beach, FL 33069-1497 U.S.A.
Tel: (954) 973-2477
Fax: (954) 979-4414
Service Hot Line: (954) 745-0150
Service Fax: (954) 973-8795
Email: onboard@marineair.com
Website: www.marineair.com



Copyright 2000 Taylor Made Environmental, Inc., All Rights Reserved

Every precaution has been taken in the preparation of this manual to insure its accuracy. However, Taylor Made Environmental assumes no responsibility for errors or omissions. Neither is any liability assumed for damages resulting from the use of this product and information contained herein.