

User's Manual



U-LINE
CORPORATION

**ICE-MAKERS,
COMBOS,
REFRIGERATORS,
75 BEV BEVERAGE
CENTER**

U-LINE CORPORATION LIMITED WARRANTY

U-Line Corporation warrants each U-Line product to be free from defects in materials and workmanship for a period of one year from the date of purchase; and warrants the sealed system (consisting of the compressor, the condenser, the evaporator, the hot gas bypass valve, the dryer and the connecting tubing) in each U-Line product to be free from defects in materials and workmanship for a period of five years from the date of purchase. During the initial one-year warranty period for all U-Line products U-Line shall: (1) at U-Line's option, repair any product or replace any part of a product that breaches this warranty; and (2) for all Marine, RV and Domestic U-Line products sold and serviced in the United States (including Alaska and Hawaii) and Canada, U-Line shall cover the labor costs incurred in connection with the replacement of any defective part. During years two through five of the warranty period for the sealed system, U-Line shall: (1) repair or replace any part of the sealed system that breaches this warranty; and (2) for all Marine, RV and Domestic U-Line products sold and serviced in the United States (including Alaska and Hawaii) and Canada, U-Line shall cover the labor costs incurred in connection with the replacement of any defective part of the sealed system. All other charges, including transportation charges for replacements under this warranty and labor costs not specifically covered by this warranty, shall be borne by you. This warranty is extended only to the original purchaser of the U-Line product. The Registration Card included with the product should be promptly completed by you and mailed back to U-Line or you can register on-line at www.U-LineService.com.

The following are excluded from this limited warranty: installation charges; damages caused by disasters or acts of God, such as fire, floods, wind and lightning; damages incurred or resulting from shipping, improper installation, unauthorized modification, or misuse/abuse of the product; customer education calls; food loss/spoilage; door and water level adjustments (except during the first 90 days from the date of purchase); defrosting the product; adjusting the controls; door reversal; or cleaning the condenser.

If a product defect is discovered during the applicable warranty period, you must promptly notify either the dealer from whom you purchased the product or U-Line at P.O. Box 23220, Milwaukee, Wisconsin 53223 or at 414-354-0300. In no event shall such notification be received later than 30 days after the expiration of the applicable warranty period. U-Line may require that defective parts be returned, at your expense, to U-Line's factory in Milwaukee, Wisconsin, for inspection. Any action by you for breach of warranty must be commenced within one year after the expiration of the applicable warranty period.

This limited warranty is in lieu of any other warranty, express or implied, including, but not limited to any implied warranty of merchantability or fitness for a particular purpose; provided however, that to the extent required by law, implied warranties are included but do not extend beyond the duration of the express warranty first set forth above. U-Line's sole liability and your exclusive remedy under this warranty is set forth in the initial paragraph above. U-Line shall have no liability whatsoever for any incidental, consequential or special damages arising from the sale, use or installation of the product or from any other cause whatsoever, whether based on warranty (express or implied) or otherwise based on contract, tort or any other theory of liability.

Some states do not allow limitations on how long an implied warranty lasts or the exclusion or limitation of incidental or consequential damages, so the above limitations may not apply to you. This warranty gives you specific legal rights, and you may also have other rights which vary from state to state.

INTRODUCTION

Congratulations on your purchase of your U-Line product. A pioneer in the field for more than 40 years, U-Line is the world's number one manufacturer of built-in, under-counter ice making and specialty refrigeration products. U-Line dedicates 100% of its research and development to these products. The result: U-Line technology leads the market with innovation, design, depth of product line and performance.

U-Line also backs customers with a strong dealer network. U-Line's commitment to quality even extends to environmentally safe packaging. U-Line products are making life more convenient in homes, businesses, and hotels around the world.

IMPORTANT

PLEASE READ all instructions completely before attempting to install or operate the unit. All models of Ice Makers and Combos require a connection to the water supply and improper hook-up can result in substantial property damage! If you are unsure of your ability to safely connect the water supply to the unit, consult a licensed plumber for assistance.

Once you have your unit installed, we suggest you keep this manual in a safe place for future reference. Should any problems occur, refer to the **TROUBLESHOOTING** section of this manual. This information will help you quickly identify a problem and get it remedied. In the event you require assistance, please contact the dealer where you purchased your unit.

User's Manual

PLEASE RECORD YOUR MODEL'S INFORMATION

Whenever you call to request information or service, you will need to know your model number and serial number. You can find this information on the serial plate located on the inside wall of your unit and on the product registration card.

PRODUCT REGISTRATION CARD

The package containing this manual also includes your product registration information. Warranty coverage begins at the time your unit was purchased.

NOTE

Complete and mail the Product Registration Card as soon as possible to validate the registration date. You may also register the product online at www.U-LineService.com.

If you do not return your Product Registration Card, U-Line will use the date of sale to the U-Line distributor as the first date of warranty for your unit. Please also record the purchase date of your U-Line unit and your dealer's name, address and telephone number.

Model Number: _____

Serial Number: _____

Purchase Date: _____

Dealer Name: _____

Dealer Address: _____

Dealer Telephone: _____

Keep this manual and the sales receipt together in a safe place for further reference.

TABLE OF CONTENTS

INTRODUCTION.....	1
SAFETY PRECAUTIONS	4
INSTALLATION	7
LEVELING THE UNIT	9
CONNECTING THE WATER SUPPLY – ICE MAKER MODELS ONLY ..	11
GRILLE INSTALLATION	14
GLASS SHELF INSTALLATION.....	17
BUILT-IN INSTALLATION.....	18
CUSTOM DOOR PANEL INSERT.....	20
WINE RACK REMOVAL/INSTALLATION.....	25
REVERSING THE DOOR	26
REVERSING A STAINLESS STEEL DOOR.....	31
ALIGNING THE DOOR.....	32
WINE RACKS – 75 BEV	33
INITIAL START-UP AND ADJUSTING THE TEMPERATURE CONTROL.....	34
TEMPERATURE CONTROL	35
NORMAL OPERATION	37
MARINE USE	39
ADJUSTING ICE CUBE SIZE	40
LIGHT SWITCH AND BULB.....	41
LIGHT BULB REPLACEMENT	42
PROPER STORAGE AND STOCKING RECOMMENDATIONS.....	43
THE RIGHT TEMPERATURE FOR WINE.....	43
CLEANING & MAINTENANCE.....	44
DEFROSTING	47
STORAGE	48
TROUBLESHOOTING	49
IF SERVICE IS REQUIRED	51
REPLACEMENT PARTS	51
SPECIFICATIONS.....	52

SAFETY PRECAUTIONS

Do not attempt to install or operate your unit until you have read the safety precautions in this manual. Safety items throughout this manual are labeled with a Danger, Warning or Caution based on the risk type.

DEFINITIONS



This is the safety alert symbol. It is used to alert you to potential personal injury hazards. Obey all safety messages that follow this symbol to avoid possible injury or death.



DANGER



DANGER indicates an imminently hazardous situation which, if not avoided, will result in death or serious injury.



WARNING

WARNING indicates a potentially hazardous situation which, if not avoided, could result in death or serious injury.



CAUTION

CAUTION indicates a potentially hazardous situation which, if not avoided, may result in minor or moderate injury.

CAUTION

CAUTION used without the safety alert symbol indicates a potentially hazardous situation which, if not avoided, may result in property damage.

IMPORTANT

Indicates installation, operation or maintenance information which is important but not hazard related.

GENERAL PRECAUTIONS



Risk of child entrapment. Before you throw away your old refrigerator or freezer, take off the doors and leave shelves in place so that children may not easily climb inside.



- Never attempt to repair or perform maintenance on the unit until the electricity has been disconnected.
- Altering, cutting of power cord, removal of power cord, removal of power plug, or direct wiring can cause serious injury, fire and/or loss of property and/or life and will void the warranty.
- The anti-tip kit must be installed on these units if they are built-in and before it is used. Never use the wine racks or shelves as steps or a shelf to support more than their content.

CAUTION

- Do not lift unit by door handle.
- Use care when moving the unit. Some edges are sharp and may cause personal injury. Wear gloves when moving or positioning the unit.
- Never install the unit behind closed doors. Be sure front grille is free of obstruction. Obstructing free air flow can cause the unit to malfunction, and may void the warranty.
- Allow unit temperature to stabilize for 24 hours before use.
- Never use an ice pick or other sharp instrument to help speed up defrosting. These instruments can puncture the inner lining or damage cooling unit.
- Failure to clean the condenser every three months can cause the unit to malfunction. This could void the warranty.

GENERAL PRECAUTIONS (CONTINUED)

CAUTION

- Using a heater to speed up defrosting can damage the inner lining. **DO NOT** use any type of electrical heater to defrost.
- Use only genuine U-Line replacement parts. Imitation parts can reduce ice rate, cause water to overflow from ice maker mold, damage the unit, and may void the warranty.

INSTALLATION

SITE PREPARATION

Your U-Line product is designed to be installed in a wall or under a counter or freestanding.

NOTE

The 75 BEV must be ordered for right or left hand door. The 75 BEV doors are not reversible. Any reference to reversing the door, does not apply to the 75 BEV.

1. Position the unit on a flat, level surface, capable of supporting the entire weight of the unit. Remember the unit will be significantly heavier once it is fully loaded.
2. This unit requires grounded and polarized 115 VAC, 60Hz, 15A circuit (normal household current).



ELECTROCUTION HAZARD!

Electrical Grounding Required. This appliance is equipped with a three prong (grounding) polarized plug for your protection against possible shock hazards.

- **NEVER** remove the round grounding prong from the plug.
- **NEVER** use a two-prong grounding adapter.
- **NEVER** use an extension cord to connect power to the unit.

Where a two-prong wall receptacle is encountered or a longer power cord is required, contact a qualified electrician to have it replaced in accordance with applicable electrical codes.

3. Connect the water supply line. See **CONNECTING THE WATER SUPPLY** for installation requirements.

User's Manual

These U-Line products are designed so they can be installed next to a wall on either side (Figure 1).

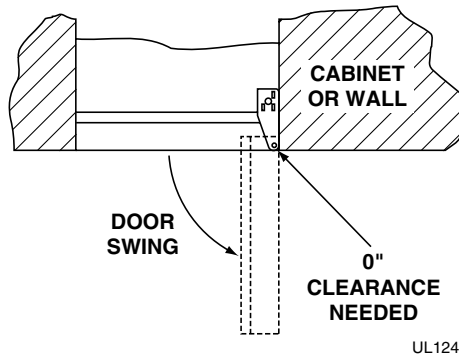

Figure 1

NOTE

Keep in mind that the door of the unit may be mounted on either side of the cabinet (see **REVERSING THE DOOR**) except for the 75 BEV. All U-Line units have a zero clearance for the door to open when the hinge is on the right, except for Stainless Steel Doors.

Additional clearance is needed for the Combo Models 29A, 29FF, and 75A only when the door hinge is on the left. See built-in installation for additional clearance requirements for these models.

Allow extra clearance, on hinge side, for a 90° door opening when installed against a wall on all Stainless Steel models.

U-Line recommends you consider additional clearance in front of the open door for convenience.

4. Position the unit to allow free air flow through the front grille (Figure 2).

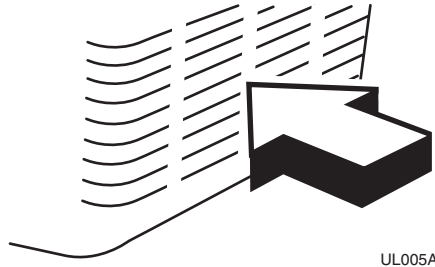

Figure 2

5. Carefully remove the grille, the glass shelves and the wine racks from inside the unit and wipe inside of unit with a clean, water dampened cloth only.

LEVELING THE UNIT

It is important that these units, primarily the ice maker assembly and 75 BEV are level. All 75 and 15 Series units are equipped with adjustable feet for leveling and height adjustment (Figure 3). All other units have rubber feet.

To level units with adjustable feet:

1. Adjust all four leveling feet evenly so that the top of the cabinet is at the desired installation height and level.
2. Using a level of at least two feet in length, measure the level of the floor where the unit is to be installed. Measure back-to-front and side-to-side and note the measurements.
3. With the unit on a level surface, adjust the feet, as appropriate, to compensate for the floor level measurements noted in Step 2.

User's Manual

- Place the unit in position where it is to be installed. Re-check cabinet height and levelness (Figure 4) and adjust if necessary.

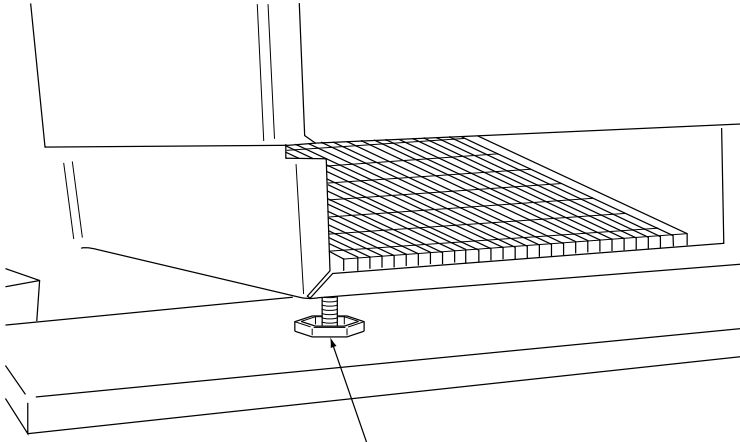

TURN FOOT TO ADJUST

UL105

Figure 3

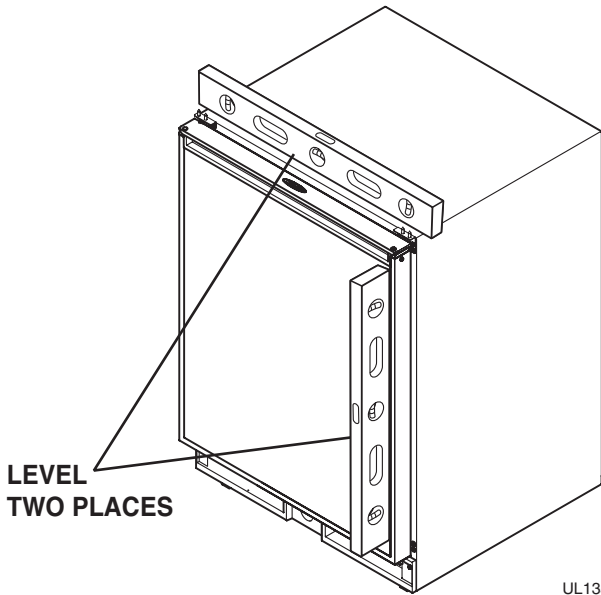

LEVEL
TWO PLACES

UL135

Figure 4

CONNECTING THE WATER SUPPLY - ICE MAKER MODELS ONLY

Install a 1/4" outside diameter copper water line (not supplied with unit) from the nearest COLD water pipe. When connecting the water supply, follow these guidelines:

- Review the local plumbing codes before you install the unit.
- In most instances, the cold water supply will come from the basement through a hole in the floor.
- The water pressure should be between 15 and 150 psi.
- Install a shut-off valve in the 1/4" outside diameter supply line (not supplied with unit).
- Connect sufficient tubing to the unit to allow the unit to be moved for cleaning and servicing. However, make certain that the tubing is not pinched or damaged during installation.
- U-Line recommends the use of copper tubing for installation.

On BI-95 and BI-98 models, the water line is inserted through the hole in the rear of the unit to connect to the solenoid valve in the front (Figure 5).

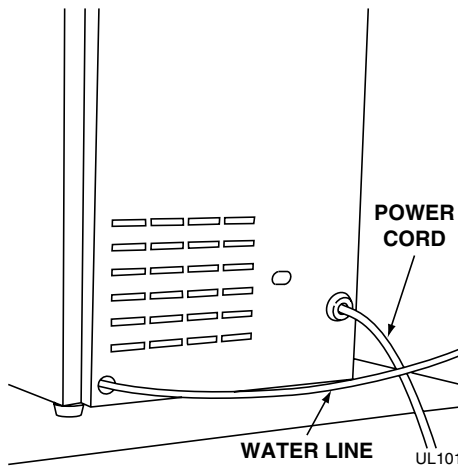
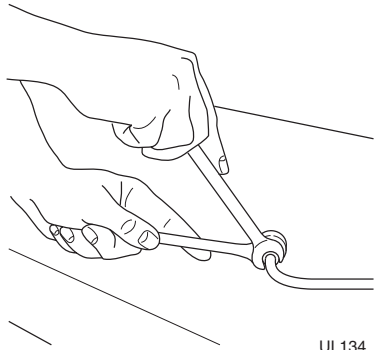

Figure 5

User's Manual

1. Locate the compression fitting and ferrule packed in the unit. Slide the compression fitting and ferrule over the 1/4" outside diameter water supply line. **Do not use thread sealing compound or tape.** Using two wrenches, tighten the compression fitting on the supply line (see Figure 6). **Do not overtighten.**



UL134_CO

Figure 6

2. Carefully bend the water supply line into position and connect the line to the solenoid valve (see Figure 7). Avoid kinking the water supply line.

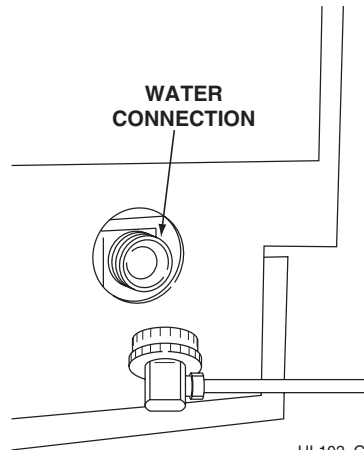

UL103_CO

Figure 7

3. For recessed installations, allow extra water supply line length to provide slack for easy removal from the recessed area (see Figure 8). This will also safeguard against kinking the line.

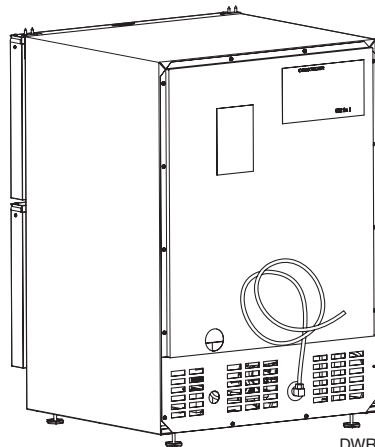

DWR033

Figure 8

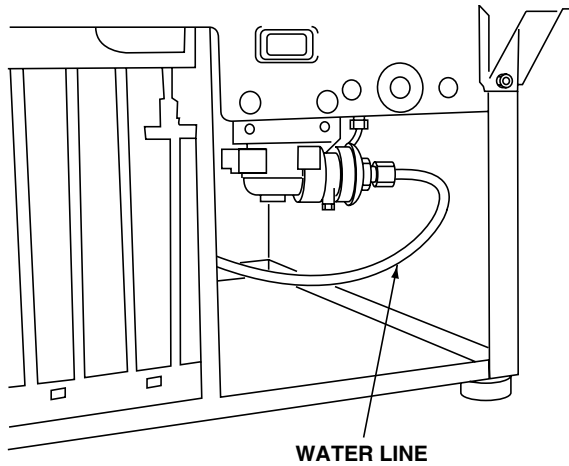

UL104

Figure 9

NOTE

On BI-95 and BI-98 models, route the water supply line through the unit so it does not come into contact with any internal components other than the solenoid valve (Figure 9). Normal operation creates some vibration. A water supply line contacting an internal component or cabinet wall can cause excessive noise during operation or damage to the line.

CAUTION

If you are not intending to use the ice maker and do not connect the water supply (or turn the supply valve off), it is imperative to raise the bucket arm of the ice maker (Figure 10). Failure to raise the bucket arm may result in damage to the water valve.

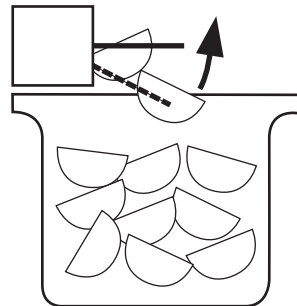

UL002A_CO

Figure 10

User's Manual

NOTE

After completing the installation, turn on the water and recheck water connection for leaks. Apply additional tightening if needed. Do not use thread sealing compound or tape.

4. Plug in the power cord.
5. Gently push the unit into position.

GRILLE INSTALLATION

1. With a standard blade screwdriver (or 1/4" nutdriver), remove the grille screw to attach the grille (Figure 11).

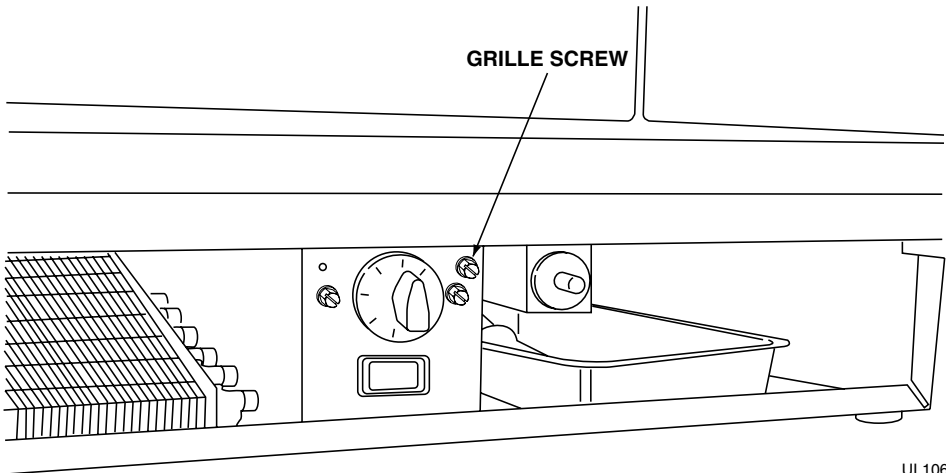

UL106

Figure 11

2. Remove the control knob by pulling it toward you.
3. Identify the small screw hole located toward the top of the middle recessed section of the grille.

- Place the two hook-hinges (located on the rear bottom side of the grille) on the front lip of the unit base. Swing the grille up into position, aligning the grille and cabinet screw hole (Figure 12).

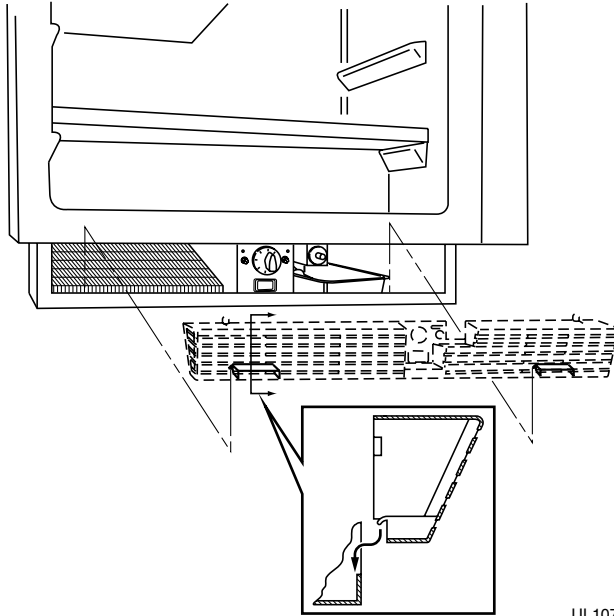

UL107

Figure 12

- Insert the screw. Do not to overtighten.
- Reinstall control knob.

User's Manual

95 AND 98 MODELS

1. With a standard blade screwdriver (or 1/4" nutdriver), remove the screw needed to attach the grille (see Figure 13).
2. Carefully remove the grille from inside the unit. Locate the screw hole at the top, middle recessed section of the grille.
3. Place the two hook-hinges (located on the rear bottom side of the grille) on the front lip of the unit base. Swing the grille up into position, aligning the grille and cabinet screw holes (see Figure 14).

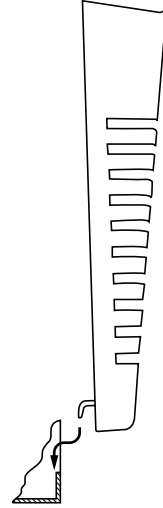

UL501

Figure 13

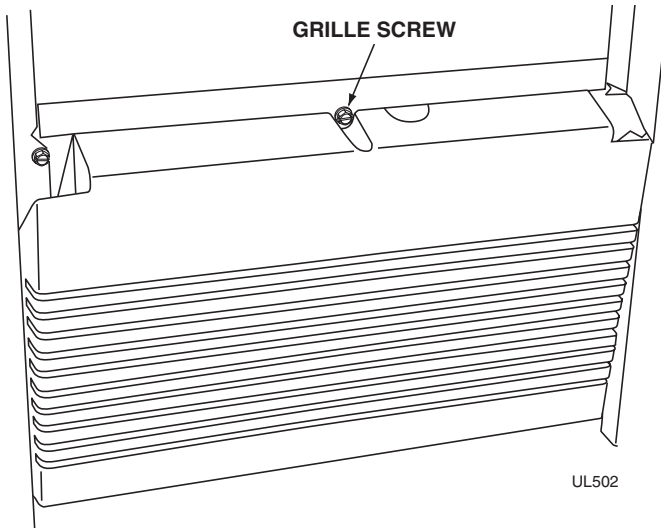

UL502

Figure 14

4. Insert the screw, being careful not to over tighten.

GLASS SHELF INSTALLATION (for models with Glass Shelves)

1. Carefully remove the glass shelves from the packaging.

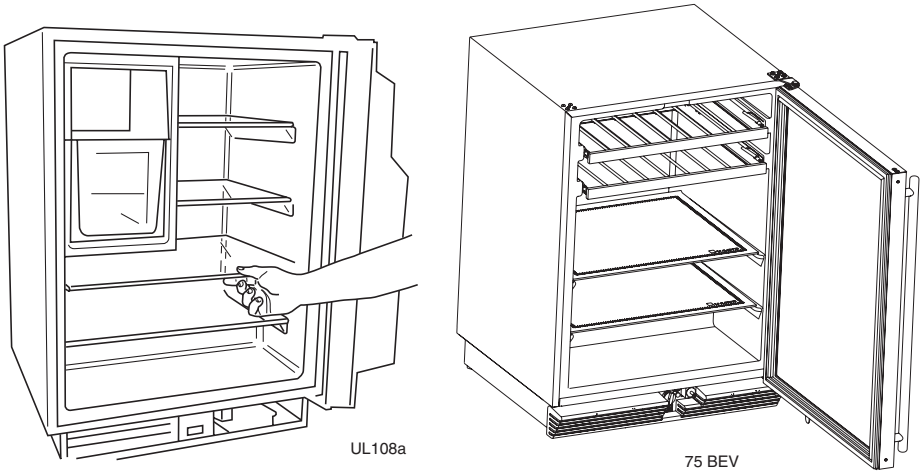

Figure 15

2. Slide the shelves onto lower two sets of ribs, making sure the silver edge strip is toward the front of the unit and the decorative graphics are on the underside of the shelves. Make sure the shelves are inserted fully into the unit (Figure 15). The white edge strip toward the rear prevents cans and bottles from freezing against the cold evaporator.

NOTE

Be sure to place shelves with the silver edge to the front and decorative graphics on the underside. 75 BEV does not have a silver edge strip.

BUILT-IN INSTALLATION

Your U-Line product is designed to be built-in or freestanding. When built-in, they do not require additional air space for the top, sides, or rear. However, the front grille must NOT be obstructed.

NOTE

Required for ease of installation and door opening, you must allow an additional 1/4" to width of unit.

Unit Dimensions

NOTE

29A, 29FF Combo Models, and 75A require additional clearance when the door opens from the right (Figures 16 and 17). This additional clearance allows for the ice bucket to be removed from the unit.

Model	Width	Height	Depth *
SP18	13-15/16"	18-1/2"	25-1/4"
95	13-13/16"	24-3/4"	17"
98	14-13/16"	27-3/8"	20"
15 Series	14-15/16"	34-35"	23-3/4"
29 Series	20-13/16"	28-1/2"	24"
75 Series	23-7/8"	34-35"	24"
75 BEV	23-15/16"	34-35"	24"

**AT LEAST 1" CLEARANCE REQUIRED IF
UNIT IS INSTALLED FLUSH WITH
CABINET OR WALL.**

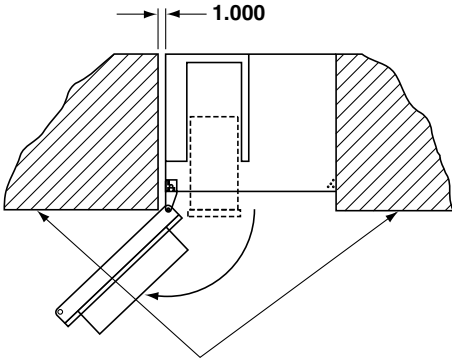

CABINET OR WALL
Figure 16

UL126

**AT LEAST 9" REQUIRED IF UNIT IS
INSTALLED ADJACENT TO
CABINET OR WALL.**

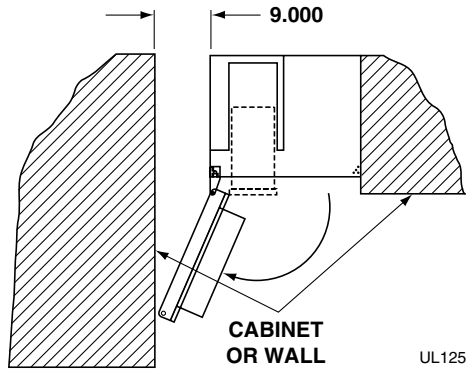

**CABINET
OR WALL**
Figure 17

UL125

CUSTOM DOOR PANEL INSERT

NOTE

The SP18 and 75 BEV models are not designed to accept custom door panels.

A custom door panel can be installed on your U-Line unit to harmonize with or accent the surrounding decor.

The door will accept a flat or raised panel. The maximum panel thickness where inserted into the door reveal (channel) is 1/4" thick. For raised panels, the depth of the reveal is 1/4" on the sides and bottom, and 1/2" on the top. The size of the door panel insert is shown below:

IMPORTANT

The door panel insert must not weigh more than 20 lbs.

Custom Door Panel Dimensions

Model	A	B
BI-95	13-15/32"	12-15/16"
BI-98	15-15/16"	13-15/16"
75 Series	28-5/32"	22-15/16"
75 SS	29-13/32"	22-15/16"
29 Series	21-13/32"	19-13/16"
15 Series	28-5/32"	13-15/16"
15 SS	29-13/32"	13-15/16"

SS - Stainless steel units

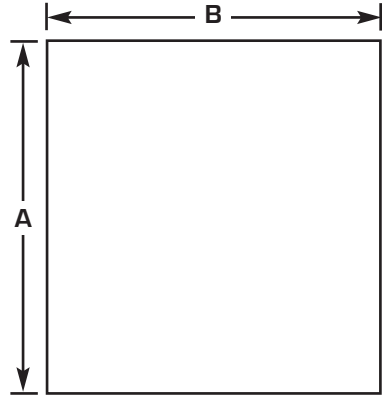

Install the insert as follows:



WARNING

Insert edges may be **SHARP!** Use care when installing.

1. Remove top hinge screw pin (large Phillips head, Figure 19). Hold door to keep it from falling.
2. Remove door, being careful not to scratch top of door on hinge.
3. Pull door gasket out of groove (top edge of door only). Start in the middle and pull outward, moving toward the edge (Figure 20). This may take some force.

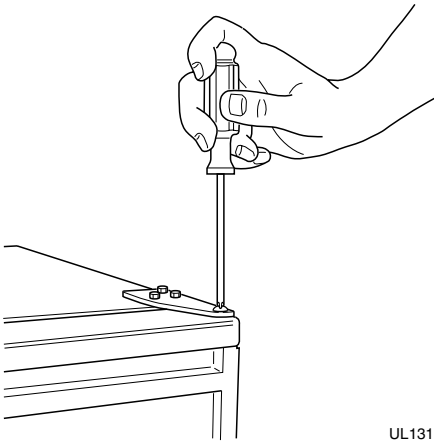

UL131

Figure 19

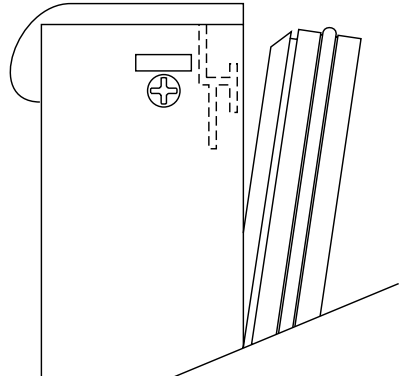
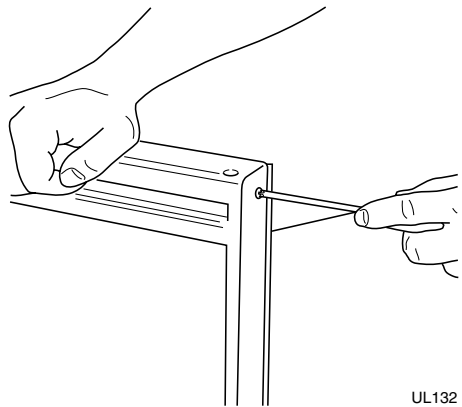

Figure 20

4. Remove two small screws holding door handle. Slightly separate door handle from door (Figure 21).
5. Pull handle up and off.



UL132

Figure 21

User's Manual

NOTE

Use care not to bend light switch bracket (where installed), located on door bottom when installing door insert. Do not set door on bottom edge when pushing insert into place.

6. Slide custom door panel insert into 1/4" channel in door front.
7. Holding door gasket out of the way, replace handle on door making sure it is seated properly on insert and that screw holes line up.
8. Install two small screws removed in step 4.
9. Starting at the corners and working inward, push door gasket into place on door.
10. Place door on bottom hinge pin and install upper hinge screw (Figure 19).
11. Reinspect door seal and alignment. Adjust if needed.

WOOD TRIM ON WINE RACKS

Your 75 BEV is equipped with a natural wood trim on the wine racks. For appearance and durability, the wood trim has been coated at the factory with a clear vinyl sealer, which will adequately protect the wood in normal usage.



WARNING

To prevent permanent damage to the inner liner of your 75 BEV, the wine rack wood trim **MUST** be removed from the unit for staining and/or finishing. Allow stain/finish to dry thoroughly (at least 24 hours per coat) in accordance with the stain/finish manufacturer's instructions prior to re-installing the wood trim inside the cabinet of the 75 BEV. Failure to do so may cause the inner liner of the unit to have a permanent odor, which is not covered by the warranty.

You have three options regarding the wood trim on the wine racks. (1) You can leave as is, (2) add a final finish coat or (3) you may stain the wood trim. The final finish coat was not applied at the factory so that the wood trim could be stained. **YOU CANNOT STAIN THE WOOD TRIM ONCE YOU APPLY THE FINAL FINISH.** Review the following guidelines when staining and or sealing the wood to ensure proper adhesion and durability of the finish.

To add a final finish coat:

1. Remove the top two racks. See **WINE RACK REMOVAL/INSTALLATION**.
2. Remove screws securing wood trim to the two racks attached at the drawer slides so wood can be removed for treatment.
3. Lightly scruff sand the wood trim with 280 grit 3M™ Tri-M-It™ sandpaper.
4. Remove sanding dust with a clean, dry cloth.
5. Apply a thin coat of a clear protective finish; the factory-applied seal is compatible with virtually all finishes. A low odor, water clean up, quick drying finish such as Minwax® Polycrylic® Protective Finish is recommended. Follow container label for directions.
6. Lightly sand and reapply if desired.

User's Manual

To stain for a different wood color:

1. Remove the top two racks. See **WINE RACK REMOVAL/INSTALLATION**.
2. Remove screws securing wood trim to the two racks attached at the drawer slides so wood can be removed for treatment.
3. Apply Minwax® Water-Based Wood Stain to wood with a synthetic bristle brush or a foam applicator. Stain must penetrate approximately three minutes. After this period, while stain is still wet, take a stain dampened rag and remove all excess stain. Wipe in the direction of the grain with medium pressure to achieve the desired stain color.
4. After two hours, repeat step 3. This will even out the color of the wood.
5. Allow stain to dry for a minimum of three hours before finishing.
6. If desired sand the wood with very fine sandpaper to smooth the surface from the staining process.
7. Remove all dust from the wood. Apply one coat of Minwax® Polycrylic® Protective Finish with a synthetic bristle brush to the wood. This finish should be applied in a thin coat following the direction of the grain. First apply the finish to the back and sides of the wood. Allow this to dry for two hours. Next apply the finish to the front side of the wood and allow to dry for two hours. Sand with very fine sandpaper (220 grit). Reapply in the same manner three times. After the third coat do not sand the surface.
8. Allow the final coat to dry for 24 hours before installing the wood to the racks.

Minwax® Polycrylic® is an ultra fast-drying water-based finish.

WINE RACK REMOVAL/INSTALLATION

To remove the wine racks for cleaning or refinishing:

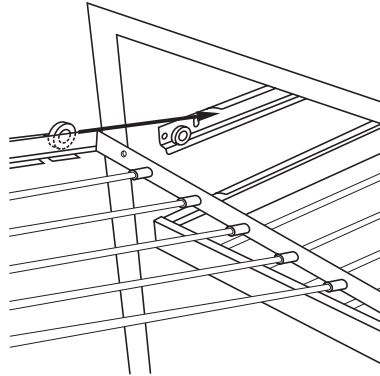

UL302

Figure 22

1. Grasp the end of the wine rack, sliding it out and up.
2. Clean wine rack with a clean dampened cloth.

To insert the wine racks:

1. Position the wine rack above the shelf channel where the rack is to be inserted (Figure 22).
2. Slide the rack on the channel at an angle until the rack is in the channel.
3. Continue sliding until the rack is all the way into the cabinet.

REVERSING THE DOOR

Depending upon the location of the unit, it may be desirable to change the side on which the door is mounted.

NOTE

On Combo Models 29A and 29FF (built-in installations only), changing the door mounting to the left side may interfere with ice bucket removal. See BUILT-IN INSTALLATION section for clearance requirements.

To reverse the door mounting on Models SP18, BI-95, BI-98, 15R, 29R, Combo 29A, and Combo 29FF (except Stainless Steel models), perform the following:

1. Remove grille (one screw) (Figure 23).
2. Remove top hinge from cabinet (three screws) (Figure 24). Hold door to keep it from falling.

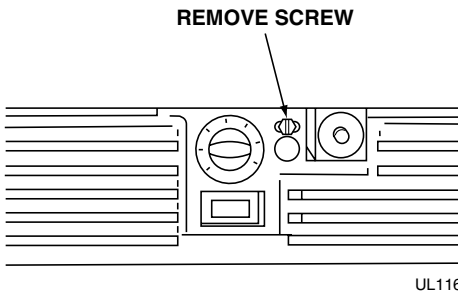

Figure 23

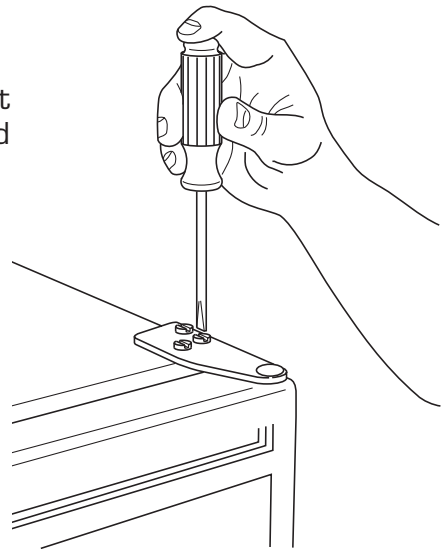
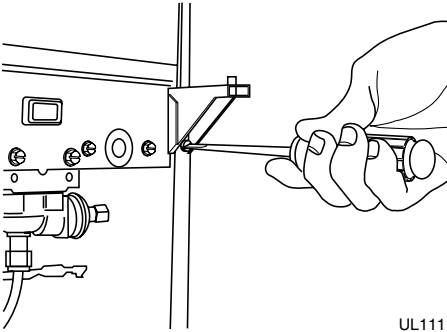

Figure 24

3. Lift the door off the bottom hinge.
4. Remove bottom hinge from cabinet (two screws) (Figure 25). Remove screws on opposite side of cabinet (Figure 26). Note that there may be a nut behind one or both screws on either side.
5. Install hinge on opposite side, bottom of cabinet (Figure 27). Replace nut on back side where installed. Align hinge outer edge with cabinet before tightening screws.



UL111

Figure 25

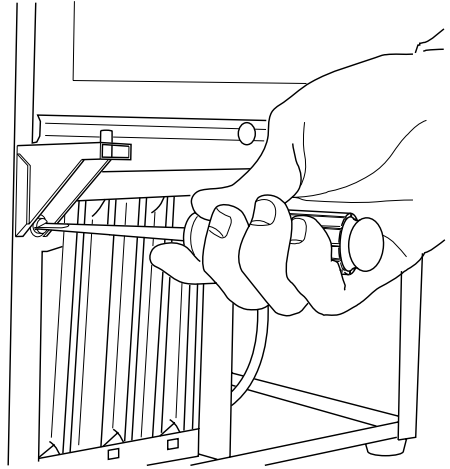

UL112

Figure 27

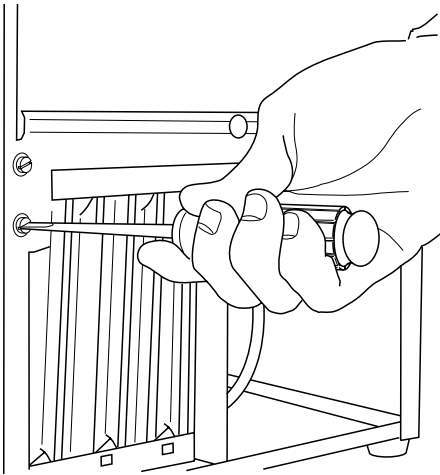

UL110

Figure 26

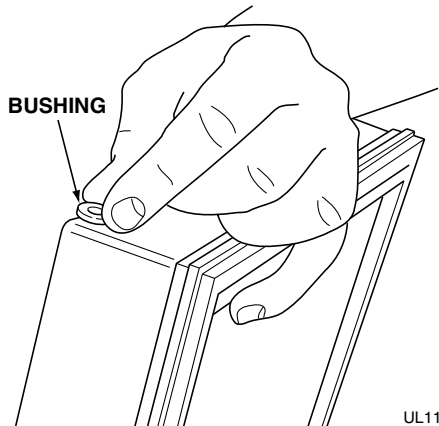

UL113

Figure 28

6. Relocate plastic spacer/bushing on bottom of door to opposite side, and place door on bottom hinge pin (Figure 28). Clean out bushing hole in door bottom with a screwdriver if needed.
7. Remove plastic hole plug from door handle and relocate on opposite side (Figure 29).

User's Manual

8. Remove pivot screw from top hinge, invert screw and reinstall pivot screw in top hinge (Figure 29).

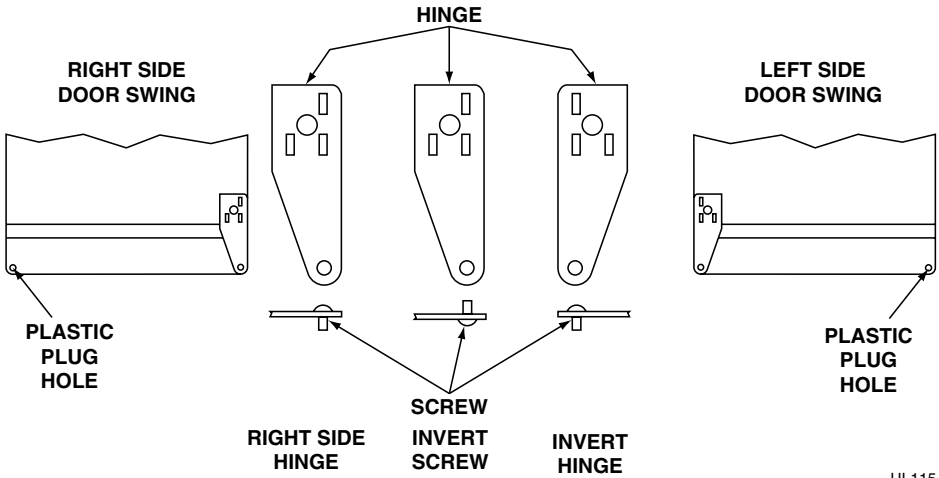

UL115

Figure 29

9. Remove three plastic screw plugs in hinge holes, top of cabinet, opposite side. Be careful not to scratch cabinet (Figure 30).
11. Fasten upper hinge to unit (three screws). Partially tighten screws until door is aligned (Figure 31).

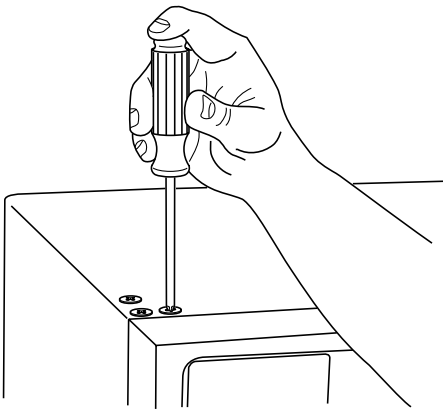

UL114A

Figure 30

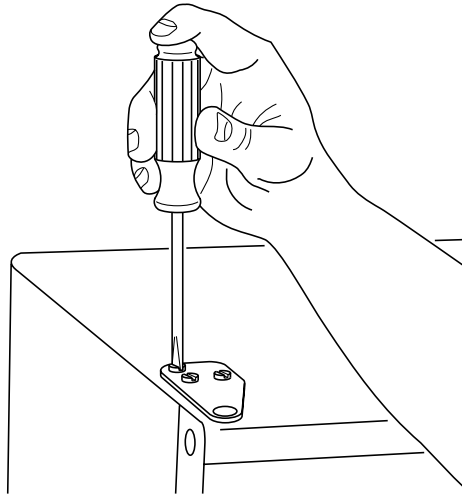

UL119

Figure 31

10. Place door on lower hinge pin. Invert and install upper hinge on door.

12. Adjust door to assure proper seal. Tighten upper hinge screws securely.
13. Replace three plastic plugs removed in step 8 into holes on top of unit. Replace screws in holes in bottom of unit, opposite side.
14. Reinspect door seal and alignment. Adjust if needed.
15. Reinstall grille (one screw).

NOTE

On Combo Model 75A (built-in installations only), changing the door mounting to the left side may interfere with ice bucket removal. See BUILT-IN INSTALLATION section for clearance requirements. The 75 BEV is not reversible. Any reference to reversing the door does not apply.

To reverse the door mounting on Models Combo 75A and 75R (except Stainless Steel models) perform the following:

1. Remove grille (one screw) (Figure 23).
2. Remove top hinge from cabinet (four screws) (Figure 24). Hold door to keep it from falling.
3. Lift the door off the bottom hinge.
4. Remove four plastic plugs in hinge holes, top of cabinet, opposite side (Figure 30). Be careful not to scratch cabinet.
5. Remove pivot screw from top hinge, invert screw and reinstall pivot screw in top hinge (Figure 29). Do not install hinge on cabinet at this time.
6. Remove bottom hinge from cabinet (four screws) and screws on opposite side of cabinet (Figure 32).
7. Remove pivot screw from bottom hinge, invert screw and reinstall pivot screw in hinge (Figure 29).

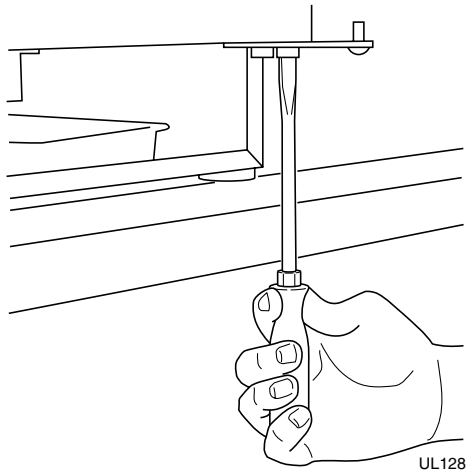

Figure 32

User's Manual

8. Install bottom hinge on cabinet, opposite side, aligning flat edge of hinge with outer edge of unit. Partially tighten screws (Figure 33).
9. Relocate plastic spacer/bushing on bottom of door to opposite side (Figure 28). Clean out bushing hole in door bottom with a screwdriver if needed.

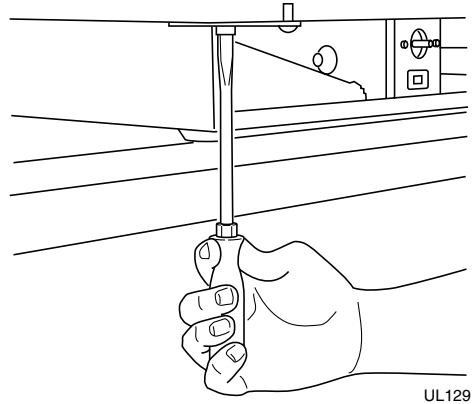

Figure 33

10. Place door on lower hinge pin. Align flat edge of top hinge with outer edge of unit and fasten upper hinge to unit (four screws). Partially tighten screws until door is aligned (Figure 31).
11. Adjust door to assure proper seal. Tighten upper and lower hinge screws securely.
12. Replace four plastic plugs removed in step 5 into holes on top of unit. Replace screws in holes in bottom of unit, opposite side.
13. Reinspect door seal and alignment. Adjust if needed.
14. Reinstall grille (one screw).

REVERSING A STAINLESS STEEL DOOR

Stainless Steel models are field reversible for left or right hand opening. The door opening is easily reversed by moving the hinge hardware to the opposite side (Figure 34) as follows:

1. Remove the bottom hinge (two screws) from door.
2. Remove top hinge (two screws) from door.
3. Remove door.
4. Remove top hinge (four screws) from cabinet. Invert and install on bottom, opposite side of cabinet.
5. Remove bottom hinge (four screws) from cabinet. Invert and install on top, opposite side of cabinet.
6. Attach top hinge to door.
7. Attach bottom hinge to door.
8. Align as required to assure proper door seal.

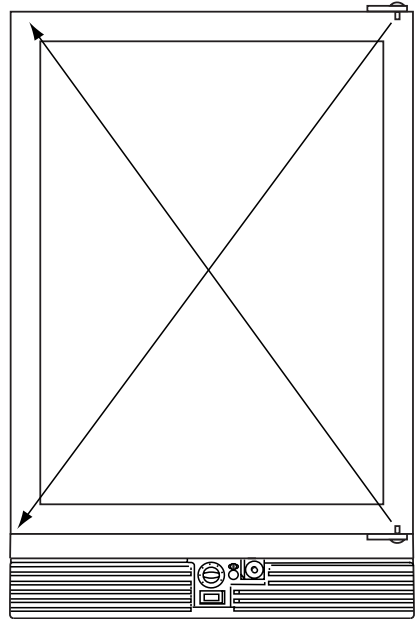

UL318C

Figure 34

ALIGNING THE DOOR

For proper door alignment:

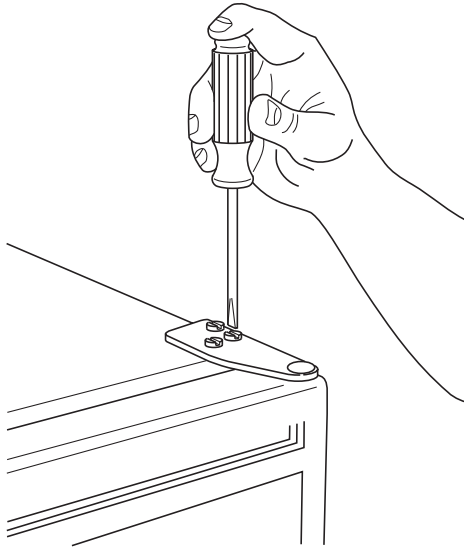

UL109

Figure 35

1. Loosen top and bottom hinge screws (Figure 35).
2. Align door squarely with cabinet.
3. Make sure the gasket is firmly in contact with cabinet all the way around the door (no gaps).
4. Tighten bottom hinge screws.
5. Tighten top hinge screws.

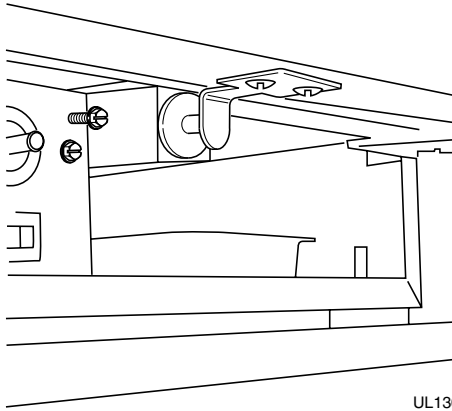

Figure 36

NOTE

When inspecting door alignment, make sure the light switch bracket makes contact with the light switch plunger (Figure 36). Also, make sure the door gasket is not pinched on the hinge side of the door.

WINE RACKS – 75 BEV

The two wine racks in the 75 BEV are designed for storage as well as for display purposes. The racks hold up to eight bottles (750 ML size) each.

When the Beverage Center door is opened, the wine racks can be slid outward by pulling on the front of the racks. This feature provides presentation and maximizes access to the bottles. This also allows you to easily identify the bottles or labels.

Open and close the wine racks, with a slow and steady motion.

NOTE

Open and close the racks slow and steady.

INITIAL START-UP AND ADJUSTING THE TEMPERATURE CONTROL

IMPORTANT

U-Line recommends the unit be allowed to run overnight and make ice on ice-maker models prior to loading with product.

It is possible that dirt or scale will dislodge in the water line. Always throw away all ice cubes made during the first two to three hours of operation.

Once the installation is complete, the unit is ready for initial start-up and operation.

NOTE

BI-95 and BI-98 models have the ON-OFF switch behind the front grille. A small opening in the top of the grille is provided to access the switch (Figure 37).

Some models may also turn off when the temperature control is turned all the way toward warmer until it stops (clicks).

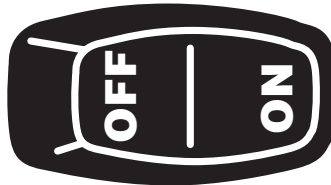

UL127A

Figure 37

1. Wipe out inside of unit, again, with a clean, water-dampened cloth.
2. Plug the appliance cord into a 115V polarized, grounded electrical outlet.
3. Check that the ON-OFF switch is in the ON position. (All units are shipped in the ON position.)

IMPORTANT

Allow unit temperature to stabilize for 24 hours before use.

- Open the water supply valve in the main water source. As soon as the ice maker mold reaches the proper temperature, the ice maker mechanism will fill the mold with water. The first cubes may be small because of air in the water line. Subsequent cubes will be of standard size. Approximate time for the first cycle is 45 minutes. Allow two hours for Frostfree models.

TEMPERATURE CONTROL

Models BI-95 and BI-98: Use a flat tip screwdriver to turn adjusting screw, located behind front grille, clockwise for colder (slower ice production) or counterclockwise for warmer (faster ice production) (Figure 38).



Figure 38

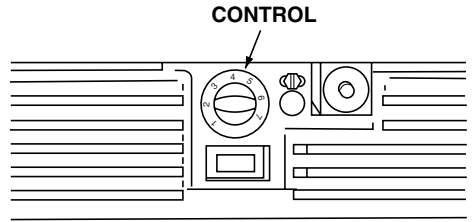

Figure 39

Series 15, 29 and 75: Adjust control setting by turning the numbered dial (Figure 39).

NOTE

Model SP18 temperature control has been preset at the factory for optimum ice production. Do not attempt to make adjustments.

User's Manual

Factors which affect the internal temperatures of the cabinet include:

1. Temperature setting.
2. Room temperature where used or installed.
3. Number of times the door is opened and closed.
4. Amount of time the internal light is illuminated. This affects primarily wines on the top racks.
5. Use or installation in direct sun light or near a heat source.

NORMAL OPERATION

On units with refrigerator sections, the unit has been designed to achieve a fresh food temperature of approximately 38°F. Units with a freezer section (ice maker) are designed to have a freezer temperature of approximately 15°F.

On units with ice makers, when the ice bucket is full, the ice making mechanism will shut off. However, the refrigeration system will continue to cool and maintain the cube supply. On frost free icemaker units, ice production will be lower than on manual defrost units.

Ice production may be interrupted by raising the bin arm into an upright and locked position (the unit will maintain temperature for ice storage, Figure 10).

On Combo units, the refrigerator fresh food temperature may vary during the initial manufacture of ice. It is recommended that the ice bucket be allowed to fill before placing food in the refrigerator section. The temperature control may then be adjusted as needed (allow 24 hours for temperature stabilization).

Certain sounds are normal during the unit's operation. You may hear the compressor or fan motor, the water valve, sounds of defrost, or ice dropping into the ice bucket.

CAUTION

NEVER use an ice pick, knife, or other sharp instrument to separate cubes. **Shake the bucket instead.**

The ice bucket **MUST** be in place to avoid freezing products in the refrigerator section of the Combo Series 29 and 75.

During periods of limited usage or high ambient temperatures, it is common for cubes to fuse together. Break apart cubes as necessary by shaking bucket.

NOTE

Control has been preset at the factory. Allow unit to run for 24 hours for temperature stabilization. This factory preset allows for optimal temperature.

User's Manual

If ice maker is not used regularly, the ice bucket should be emptied periodically to ensure fresh cubes.

It is normal for cubes to appear cloudy. This is caused by air being trapped in the water due to fast freezing. It has nothing to do with the health, taste or chemical make-up of the water. It is the same air that is in every glass of water you drink.

To provide for higher ice rate (production of more cubes), adjust the temperature control to a **warmer** setting. If hollow cubes result, adjust temperature somewhat **colder**. For less cube production, adjust to a **colder** setting.

The ice bucket must be fully inserted in the freezer section.

The ice bin door must be fully closed.

For frost free models: Do not place any objects over air inlet or outlet in freezer section.

For frost free models: Light frosting may occur in high humidity conditions or if the ice bucket is not pushed in completely.

MARINE USE

Many U-Line models are designed to operate in a harsh marine environment. Special considerations include the following:

- For best performance, keep the unit out of direct sunlight.
- On Ice Maker models, turn the unit OFF and dispose of any ice cubes if the unit will not be used for five days or more. Prop door open to allow for air circulation and prevent mold and mildew. Do not use anti-freeze in your icemaker.
- If the ambient temperature is expected to drop below 45°F, drain all water from the unit to prevent freezing damage not covered by the warranty.
- High ambient temperatures (110°F or higher) may reduce the unit's ability to reach low temperatures and may also reduce the ice production rate.

ADJUSTING ICE CUBE SIZE

On models equipped with an ice maker, the cube size may be adjusted by changing the amount of water injected into the ice maker assembly.

1. Remove the ice maker assembly cover (Figure 41).
2. Locate the adjusting screw on the ice maker assembly control box. The adjusting screw is just below the minus (-) and plus (+) signs on the control box (see Figure 42).

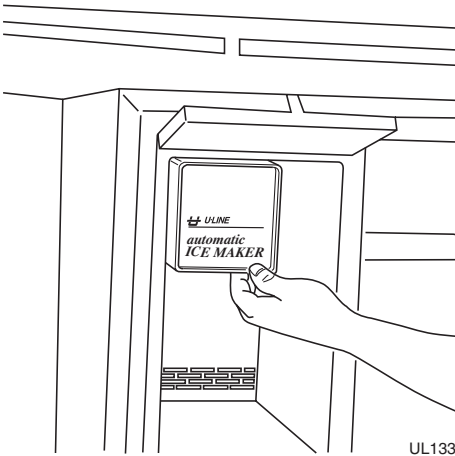

Figure 41

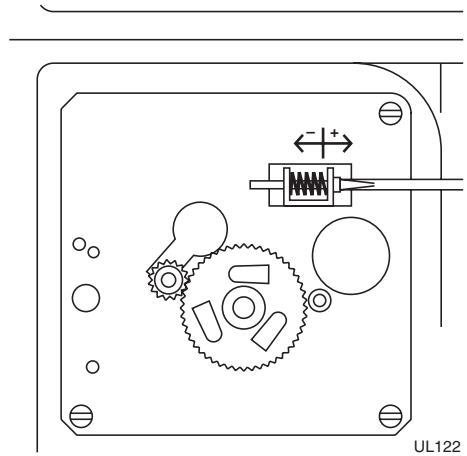

Figure 42

3. Turn the adjusting screw toward the minus (-) sign (clockwise) for smaller cubes or toward the plus (+) sign (counterclockwise) for larger cubes.
4. Install the ice maker assembly cover. Some units are not frost free and must be defrosted periodically. Refer to CLEANING AND MAINTENANCE.

NOTE

Be sure to make water and temperature adjustments in small increments. Too big of an adjustment could cause the unit to malfunction.

CAUTION

Use only genuine U-Line replacement parts. U-Line ice maker parts are not the same as standard FSP Whirlpool parts. Using non U-Line parts can reduce ice rate, cause water to overflow from ice maker mold, damage the unit, and may void the warranty. Using non U-Line parts can reduce ice rate, cause water to overflow from ice maker mold, damage the unit, and may void the warranty.

LIGHT SWITCH AND BULB

All 75 Series units have interior lights, which are illuminated when the door is opened. The 75 BEV allows you to display your wines for those “special occasions” while the door is closed. Just depress the switch located to the right of the control dial on the grille to the ON position.

NOTE

When the light is on for an extended period of time it will increase the cabinet temperature, especially at the top.

LIGHT BULB REPLACEMENT

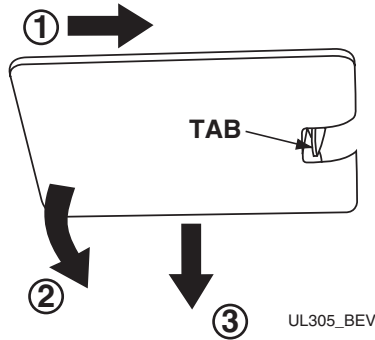

Figure 43

Light bulb replacement is simple.

1. Remove the light housing cover by sliding the cover toward the tab, swinging the end opposite the tab down and pulling down and away (Figure 43).
2. Replace bulb with genuine ULine replacement.



WARNING

Do not use any other replacement bulb than the one recommended.

3. Replace the light housing cover by inserting the tab FIRST, sliding the cover toward the tab and pushing up the other end. You should hear a snap/click.

PROPER STORAGE and STOCKING RECOMMENDATIONS

Your Beverage Center will accommodate up to 16 bottles (750 ML size) on the wine racks: up to eight bottles on each rack. Specially designed wine racks allow for the proper horizontal storage and presentation of the wine. The cork remains moist, which keeps air from entering the bottle.

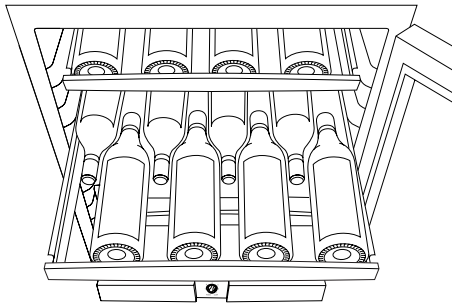

UL138

Figure 44

The 75 BEV should be stocked beginning at the back of the bottom rack and working forward. Stagger the bottles as shown in Figure 44. The top rack should be stocked similarly, starting at the back and working forward.

THE RIGHT TEMPERATURE FOR WINE

The 75 BEV wine racks permit storage of your finest wines at approximately 45°F. The glass shelves are approximately 38°F. Temperatures noted are product temperatures and not air temperatures.

CLEANING & MAINTENANCE

Periodic cleaning and proper maintenance will ensure efficiency, top performance, and long life. The maintenance intervals listed are based on normal conditions. You may want to shorten the intervals if you have pets, the unit is used outdoors, or other special considerations.

Exterior Cleaning – As Required

The door, grille and cabinet may be cleaned with a mild detergent and warm water solution. Do not use solvent based or abrasive cleaners. Use a soft sponge and rinse with clean water. Wipe with a soft, clean towel to prevent water spotting.

Stainless steel models can discolor when exposed to chlorine gas and should be cleaned with a mild detergent and warm water solution and a damp cloth. **Never use abrasive cleaning agents.**

CAUTION

Stainless steel models exposed to chlorine gas and moisture, such as areas with spas or swimming pools, may have some discoloration of the stainless steel. Discoloration from chlorine gas is normal.

Interior Cleaning – As Required

1. Disconnect power to the unit.
2. Remove all the inside racks and shelves. Wipe down the interior, racks and shelves with a solution of mild detergent and warm water. Do not use solvent based or abrasive cleaners. Do not place any component in a dishwasher.
3. Rinse thoroughly with clear water.
4. Reconnect power to the unit.



WARNING

DO NOT use solvent cleaning agents or abrasives on the interior. These cleansers may damage or discolor the interior.

Condenser Cleaning – Every Three Months**WARNING**

Disconnect electric power to the unit before cleaning the condenser or the solenoid valve.

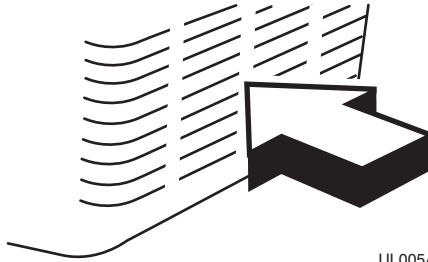

UL005A

Figure 45

Keep the front grille free of dust and lint to allow air to flow to the condenser (Figure 45). Clean the condenser coil, located behind the front grille. Use a brush or vacuum cleaner to remove dirt, lint and other accumulations from the condenser coil.

To remove and replace the grille for access to the condenser fins follow this procedure:

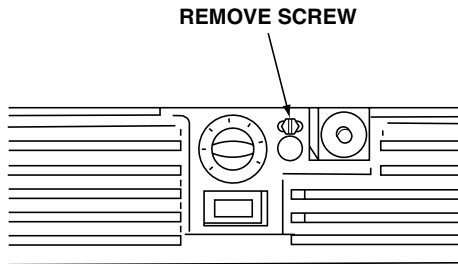

UL116

Figure 46

1. With a standard blade screwdriver (or 1/4" nutdriver), remove the grille screw (Figure 46).
2. Remove the control knob by pulling it toward you.
3. Remove the grille.



WARNING

DO NOT touch the condenser fins. The condenser fins are SHARP and can be easily damaged.

4. Clean the condenser coil using a soft brush with a “combing” action or vacuum cleaner. Do not touch the condenser coil. The condenser coil may be located on either the right or left side of the base.

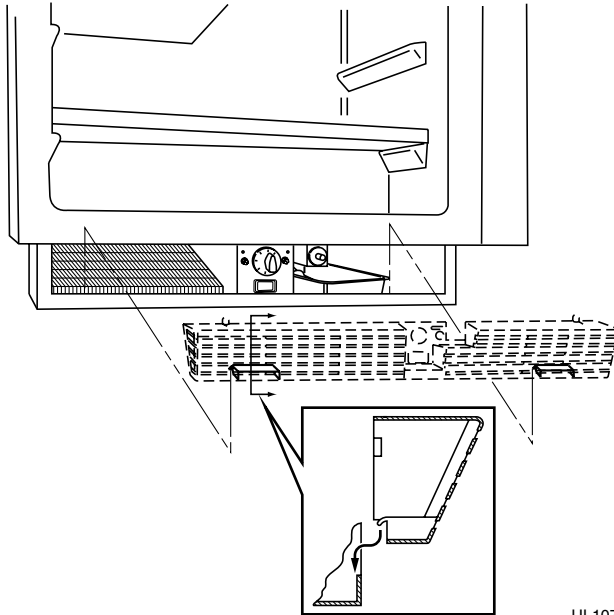

UL107

Figure 47

5. Place the two hook-hinges (located on the rear bottom side of the grille) on the front lip of the unit base. Swing the grille up into position, aligning the grille and cabinet screw hole (Figure 47).
6. Position the grille to align the screw holes with the cabinet.
7. Insert the grille screw and tighten. Do not overtighten.

The solenoid valve inlet screen must be cleaned at least once each year as follows:

1. Shut off the water at the water supply valve.
2. Remove the entire hose connector from the solenoid valve.

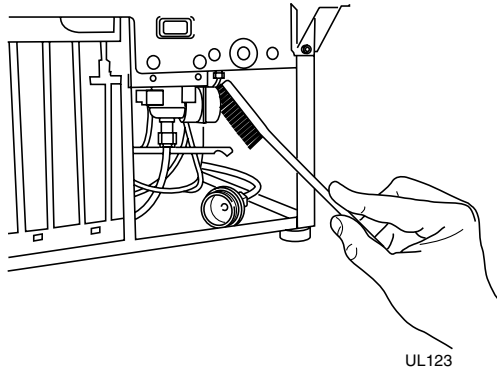

Figure 48

3. Use a tooth brush to clean sediment from the inlet screen (Figure 48). **DO NOT** remove the screen.
4. Attach the hose connector to the solenoid valve. Tighten connector securely with pliers. Open the water supply valve and check for leaks at the hose connector.

DEFROSTING

CAUTION

DO NOT use any type of electrical heating device, ice pick, knife, or other sharp instrument to defrost, as this could damage the inner lining or refrigeration system and void the warranty.

Manual defrost models should be defrosted approximately every eight weeks. However, this interval may not be adequate in periods of high humidity or heavy usage. Defrost your unit whenever the frost thickness is 1/4" or greater. To defrost, turn the unit OFF, remove cubes and prop door open at least two inches.

NOTE

Frost free units will **NEVER** need defrosting. Automatic defrost models do not normally require manual defrosting. However, in extremely high humidity or during periods of unusually high usage, minimal manual defrosting may be required.

STORAGE

If the unit is to be stored or not used for extended periods:

1. Remove all contents from the unit.
2. Shut off water supply at the main water source.
3. Disconnect the water supply line from the solenoid valve.
4. Disconnect the water line from the solenoid valve outlet and drain the system of water.
5. Allow the unit to run for one hour or more until all remaining ice cubes have been ejected from the ice maker assembly.
6. Remove all ice from the ice bucket.
7. Dry out excess water from the ice maker assembly and ice bucket.
8. Prop the doors open at least 2" to allow for air circulation and prevent mold and mildew.
9. Disconnect unit from main electrical power source.
10. Leave water supply line and power cord disconnected until ready to reuse.

NOTE

The use of anti-freeze or other products of this nature is not necessary and is not recommended.

TROUBLESHOOTING

BEFORE CALLING FOR SERVICE

If the unit appears to be malfunctioning, read through NORMAL OPERATION first. If the problem persists, check the TROUBLESHOOTING GUIDE. Locate the problem in the guide and refer to the cause and its remedy before calling for service. The problem could be something very simple which can be solved without a service call.

TROUBLESHOOTING GUIDE



ELECTROCUTION HAZARD

NEVER attempt to repair or perform maintenance on the unit until the main electrical power has been disconnected.

Troubleshooting — What to check when problems occur

Problem	Possible Cause	Remedy
No interior light	Loose or burned out bulb	Tighten or replace bulb. See LIGHT BULB REPLACEMENT.
Light won't go out when door is closed.	Light on/off switch is turned to ON.	Turn switch to OFF. See LIGHT SWITCH AND BULB.
The unit is not cold enough	Light staying on	Adjust door so light switch bracket contacts switch plunger. See ALIGNING THE DOOR. 75 BEV - Make sure the light switch is in the "OFF" position.
	Door gasket not sealing properly	Adjust door. See ALIGNING THE DOOR.
	Item(s) interfering with door.	Reposition or remove item(s).
	Dirty condenser coils	Clean condenser. See CLEANING AND MAINTENANCE.

User's Manual

Problem	Possible Cause	Remedy
The unit is not cold enough (cont.)	Airflow to front grille blocked	Airflow must not be obstructed to front grille. See INSTALLATION or CLEANING AND MAINTENANCE.
	Temperature not set cold enough	Turn control knob CLOCKWISE to set temperature colder. Allow 24 hours for temperature to stabilize.
The unit is not cold enough (Frost free units only)	The door was left open causing the evaporator behind the back wall to fill with frost preventing proper air flow and cooling.	Turn off the unit to manually defrost the evaporator. See DEFROSTING.
The unit frosts up	Unit is manual defrost model	Models SP18, 95, 98, and Combo 29A and 75A are manual defrost. Refer to DEFROSTING.
	Door gasket not sealing properly	Adjust door. See ALIGNING THE DOOR.
	High ambient temperatures or humidity	Defrost unit manually. See DEFROSTING.
Water is leaking out the back of the unit	Water supply connection leaking	Tighten fitting. See CONNECTING THE WATER SUPPLY.
Ice cubes sticking together	Door gasket not sealing properly	Adjust door. See ALIGNING THE DOOR.
	Infrequent use of cubes	Break apart cubes.
Noise during operation	Copper water supply tubing contacting internal components	Carefully bend tubing away from cabinet and components.
	Certain sounds are normal.	Soft sounds from the fan and water/dropping sounds from the ice maker will be heard.
	Fan blade touching obstruction (wiring, foam insulation, etc.)	Remove obstruction.

Problem	Possible Cause	Remedy
No ice	Bin arm locked in upright position	Lower bin arm.
	No water to unit.	Turn on water or contact plumber.
Not enough ice	Control set too cold	Adjust control to a warmer setting (COUNTERCLOCKWISE).
	Ice cube size too large	Set cube size smaller. See ADJUSTING ICE CUBE SIZE.
	Dirty condenser coils.	Clean condenser. See CLEANING AND MAINTENANCE.
Water leaks into ice bucket	Water level set too high	Set cube size smaller. See ADJUSTING ICE CUBE SIZE.
Fresh food section on Combo units too cold	Ice bucket not fully inserted	Push ice bucket into place.
	Flap door not closed correctly	Be sure Flap door is closed correctly.
Unit too cold	Temperature control set too cold	Set control to warmer setting (COUNTERCLOCKWISE).

IF SERVICE IS REQUIRED

If the need for service arises, contact the dealer from whom the unit was purchased. State the Model Number and Serial Number and explain the problem. The Model and Serial Number plate is located inside unit at upper right hand corner, except for models 95, 98 and SP18, which have the plate located behind the ice bucket. If you do not know the name of the selling dealer or local service company, you can check on-line at www.U-LineService.com.

REPLACEMENT PARTS

Use only genuine U-Line replacement parts. Genuine U-Line parts are designed to work correctly with U-Line products and offer superior service life. The use of non-U-Line parts can damage the unit and may void the warranty.

User's Manual

SPECIFICATIONS

Unit Type	Model Number	Ice Production Capacity (per day)	Cube Storage Capacity	Fresh Food (refrigerator) Capacity	Freezer Capacity	Defrost Technology
Ice Makers	SP18	18 lbs. (8 kg)	12 lbs. (5 kg)			Manual
	BI-95	23 lbs. (10 kg)	12 lbs. (5 kg)			Manual
	BI-98	25 lbs. (11 kg)	25 lbs. (11 kg)			Manual
Combos	75A	22.5 lbs. (10 kg)	13 lbs. (6 kg)	4.2 cu. ft. (119 L)		Manual
	29FF	8 lbs. (4 kg)	13 lbs. (6 kg)	2.1 cu. ft. (60 L)		Frost Free
	29A	22 lbs. (10 kg)	13 lbs. (6 kg)	2.1 cu. ft. (60 L)		Manual
Refrigerators	75R			6 cu. ft. (170 L)		Automatic Defrost
	29R			3.5 cu. ft. (99 L)		Automatic Defrost
	15R			3.5 cu. ft. (99 L)		Automatic Defrost
Beverage Center	75 BEV			6 cu. ft. (170 L)		Automatic Defrost



P.O. Box 245040
Milwaukee, WI 53224-9540
Phone 414.354.0300
FAX 414.354.7905
www.U-Line.com

Printed in U.S.A.
P/N 30035

